

NFPA 24

Standard for the Installation of Private Fire Service Mains

and Their Appurtenances

1995 Edition

Copyright © 1995 NFPA, All Rights Reserved

This edition of NFPA 24, *Standard for the Installation of Private Fire Service Mains and Their Appurtenances*, was prepared by the Technical Committee on Private Water Supply Piping Systems and acted on by the National Fire Protection Association, Inc., at its Annual Meeting held May 22-25, 1995, in Denver, CO. It was issued by the Standards Council on July 21, 1995, with an effective date of August 11, 1995, and supersedes all previous editions.

This edition of NFPA 24 was approved as an American National Standard on August 11, 1995.

Changes other than editorial are indicated by a vertical rule in the margin of the pages on which they appear. These lines are included as an aid to the user in identifying changes from the previous edition.

Origin and Development of NFPA 24

In 1903, the NFPA Committee on Hose and Hydrants first presented *Specifications for Mill Yard Hose Houses*, taken substantially from a standard published by the Eastern Factory Insurance Association. This text was revised and adopted in 1904. The NFPA Committee on Field Practice amended the Specifications in 1926, published as NFPA 25.

In 1925 the Committee on Field Practice prepared a *Standard on Outside Protection, Private Underground Piping Systems Supplying Water for Fire Extinguishment*, which was adopted by NFPA. It was largely taken from the 1920 edition of the NFPA *Automatic Sprinkler Standard*, Section M on Underground Pipes and Fittings. In September 1931, a revision was made with the resulting standard designated as NFPA 24. In the 1981 edition the title was changed from *Standard for Outside Protection to Standard for the Installation of Private Fire Service Mains and Their Appurtenances*.

In 1953, on recommendation of the Committee on Standpipes and Outside Protection, the two standards (NFPA 24 and NFPA 25) were completely revised and adopted as NFPA 24. Amendments were made leading to separate editions in 1955, 1959, 1962, 1963, 1965, 1966, 1968, 1969, 1970, 1973, 1977, 1981, 1983, and 1987.

The 1992 edition includes amendments to further delineate the point at which the water supply stops and the fixed fire protection system begins. Minor changes have been made concerning special topics such as thrust restraint and equipment provisions in valve pits.

The 1995 edition clarifies requirements for aboveground and buried piping. Revisions were made to provide additional information regarding listing requirements, signage, valves, valve supervision, hydrant outlets, system attachments, piping materials, and thrust blocks. User friendliness of the document was also addressed.

Technical Committee on Private Water Supply Piping Systems

Richard Martineau, *Chair*
Mid Hudson Automatic Sprinkler Corp., NY
Rep. Nat'l Fire Sprinkler Assn.

David S. Mowrer, *Vice Chair*
HSB Professional Loss Control Inc., TN

Kerry M. Bell, Underwriters Laboratories Inc., IL

Richard W. Bonds, Ductile Iron Pipe Research Assn., AL

Frank E. Cann, Jr., Charlotte, NC
Rep. Grinnell Fire Protection

Kenneth J. Carl, Baldwin, NY

August F. DiManno, Jr., Firemen's Fund Insurance Co., NY

Robert M. Gagnon, Gagnon Engr, Corp., MD

David M. Gough, Industrial Risk Insurers, CT

Marshall A. Klein, Marshall A. Klein & Assn., Inc., MD

James M. Maddry, Science Applications Int'l Corp., GA

Heinz E. Otte, Waterous Co., MN
Rep. Mfrs. Standardization Society

Robert A. Panero, Pacific Gas and Electric Co., CA
Rep. Electric Light Power Group/Edison Electric Inst.

David O. Rogers, Alexander & Alexander, Inc., GA

Sam (Sat) Salwan, Environmental Systems Design Inc., IL

J. William Sheppard, General Motors Corp., MI
Rep. NFPA Industrial Fire Protection Section

James W. Simms, Rolf Jensen & Assoc., Inc., CA

Robert D. Spaulding, Factory Mutual Research Corp., MA

Michael J. Stelzer, ABB Lummus Crest, Inc., TX

Joseph E. Trigg, Jr., Potter Electric Signal Co., MO

James G. Whitelaw, Febco Sales Inc., CO

Fred S. Winters, Wausau, WI
Rep. The Alliance of American Insurers

Robert A. Yoder, Jr., M. J. Corboy Co., IL
Rep. Illinois Fire Prevention Assn.

Alternates

Walter A. Damon, Schirmer Engineering Corp., IL
(Alt. to R. A. Yoder, Jr.)

Joseph B. Hankins, Jr., Factory Mutual Research Corp., MA
(Alt. to R. D. Spaulding)

Michael L. Jones, Industrial Risk Insurers, CA
(Alt. to D. M. Gough)

Miles R. Suchomel, Underwriters Laboratories Inc., IL
(Alt. to K. M. Bell)

Lynn K. Underwood, Wausau Insurance Cos., WI
(Alt. to F. S. Winters)

David J. Vandeyar, Nat'l Fire Sprinkler Assn., NY
(Alt. to R. Martineau)

Peter R. Yurkonis, Rolf Jensen & Assoc., Inc., IL
(Alt. to J. W. Simms)

Nonvoting

Geoffrey N. Perkins, Bassett Consulting Engr, Brisbane, Australia

Milosh T. Puchovsky,
NFPA Staff Liason

This list represents the membership at the time the Committee was balloted on the text of this edition. Since that time, changes in the membership may have occurred.

NOTE: Membership on a committee shall not in and of itself constitute an endorsement of the Association or any document developed by the committee on which the member serves.

Committee Scope: This Committee shall have primary responsibility for documents on private piping systems supplying water for fire protection and for hydrants, hose houses, and valves. The Committee is also responsible for documents on fire flow testing and marking of hydrants.

NFPA 24

Standard for the Installation of Private Fire Service Mains and Their Appurtenances

1995 Edition

NOTICE: An asterisk (*) following the number or letter designating a paragraph indicates that explanatory material on the paragraph can be found in Appendix A.

Information on referenced publications can be found in Chapter 10 and Appendix B.

Chapter 1 General Information

1-1 Scope.

This standard establishes the minimum requirements for installation of private fire service mains and their appurtenances supplying automatic sprinkler systems, open sprinkler systems, water spray fixed systems, foam systems, private hydrants, monitor nozzles or standpipe systems with references to water supplies, private hydrants, and hose houses. This standard also applies to “combined service mains” used to carry water for both fire service and other use. The authority having jurisdiction shall always be consulted before installation or remodeling of private fire service mains.

1-2 Purpose.

The purpose of this standard is to provide a reasonable degree of protection for life and property from fire through installation requirements for private fire service main systems based upon sound engineering principles, test data, and field experience. Nothing in this standard is intended to restrict new technologies or alternate arrangements, providing the level of safety prescribed by the standard is not lowered.

1-3 Definitions.

Copyright NFPA

Approved.* Acceptable to the authority having jurisdiction.

Authority Having Jurisdiction.* The organization, office, or individual responsible for approving equipment, an installation, or a procedure.

Listed.* Equipment or materials included in a list published by an organization acceptable to the authority having jurisdiction and concerned with product evaluation that maintains periodic inspection of production of listed equipment or materials and whose listing states either that the equipment or material meets appropriate standards or has been tested and found suitable for use in a specified manner.

Private Fire Service Main.* Private fire service main, as used in this standard, is that pipe and its appurtenances on private property:

- (a) Between a source of water and the base of the riser for water-based fire protection systems.
- (b) Between a source of water and inlets to foam making systems.
- (c) Between a source of water and the base elbow of private hydrants or monitor nozzles.
- (d) Used as fire pump suction and discharge piping.
- (e) Beginning at the inlet side of the check valve on a gravity or pressure tank.

Shall. Indicates a mandatory requirement.

Should. Indicates a recommendation or that which is advised but not required.

Standard. A document, the main text of which contains only mandatory provisions using the word "shall" to indicate requirements and which is in a form generally suitable for mandatory reference by another standard or code or for adoption into law. Nonmandatory provisions shall be located in an appendix, footnote, or fine-print note and are not to be considered a part of the requirements of a standard.

1-4* Plans.

1-4.1

A layout plan shall be approved by the authority having jurisdiction in every case where a new private fire service main is contemplated.

1-4.2

The plan shall be drawn to scale and shall include all essential details such as:

- (a) Size and location of all water supplies.
- (b) Size and location of all piping, indicating, where possible, the class and type and depth of existing pipe, the class and type of new pipe to be installed, and the depth to which it is to be buried.
- (c) Size, type, and location of valves. Indicate if located in pit or if operation is by post indicator or key wrench through a curb box. Indicate the size, type, and location of meters, regulators, and check valves.
- (d) Size and location of hydrants, showing size and number of outlets and if outlets

are to be equipped with independent gate valves. Indicate if hose houses and equipment are to be provided and by whom.

(e) Sprinkler and standpipe risers and monitor nozzles to be supplied by the system.

(f) Location of fire department connections, if part of private fire service main system, including detail of connections.

1-5 Installation Work.

Installation work shall be done by fully experienced and responsible persons.

1-6 Units.

Metric units of measurement in this standard are in accordance with the modernized metric system known as the International System of Units (SI). Two units (liter and bar), outside of but recognized by SI, are commonly used in international fire protection. These units are listed in Table 1-6 with conversion factors.

Table 1-6

Name of Unit	Unit Symbol	Conversion Factor
per minute per square meter	L (L/min)/m ²	1 gal = 3.785 L 1 gpm/ft ² = (40.746 L/min)/m ²
decimeter	dm ³	1 gal = 3.785 dm ³
al	Pa	1 psi = 6894.757 Pa
	bar	1 psi = 0.0689 bar
	bar	1 bar = 105 Pa

For additional conversions and information, see ASTM E380-1989, *Standard for Metric Practice*.

1-6.1

If a value for measurement as given in this standard is followed by an equivalent value in other units, the first stated is to be regarded as the requirement. A given equivalent value might be approximate.

1-6.2

The conversion procedure for the SI units has been to multiply the quantity by the conversion factor and then round the result to the appropriate number of significant digits.

Chapter 2 Water Supplies

2-1 Nature of Supply.

The choice of water supplies shall be made in cooperation with the authority having jurisdiction.

2-2 Public Water Systems.

(Applicable also to private supply systems.)

2-2.1

One or more connections from a reliable public water system shall be acceptable. The capacity of the supply shall meet the needed fire flow as determined by the authority having jurisdiction.

2-2.2

Adequacy of water supply shall be determined by flow tests or other reliable means. Where flow tests are made, the flow in gallons per minute (L/min) together with the static and residual pressures shall be indicated on the plan.

2-2.3*

Public mains shall be of ample size, in no case smaller than 6 in. (152 mm).

2-2.4

No pressure regulating valve shall be used in the water supply except by special permission of the authority having jurisdiction. Where meters are used they shall be of an approved type.

2-2.5*

Where connections are made from public waterworks systems, it might be necessary to guard against possible contamination of the public supply. The requirements of the public health authority having jurisdiction shall be determined and followed. Where equipment is installed to guard against possible contamination of the public water system, such equipment and devices shall be listed for fire protection service.

2-2.6

Connections to public water systems shall be controlled by post indicator valves of an approved type and located not less than 40 ft (12.2 m) from the buildings protected.

Exception: If this cannot be done, the post indicator valves shall be placed where they will be readily accessible in case of fire and not liable to injury. (See Section 3-3 for details.)

Where post indicator valves cannot readily be used, as in a city block, underground valves shall conform to these provisions and their locations and direction of turning to open shall be clearly marked.

2-3* Pumps.

A fire pump installation consisting of pump, driver, and suction supply, when of adequate capacity and reliability and properly located, makes a good supply. An automatically controlled fire pump taking water from a water main of adequate capacity or taking draft under a head from a reliable storage of adequate capacity, shall be permitted to be, under certain conditions, accepted by the authority having jurisdiction as a single supply. Pumps shall be installed in accordance with NFPA 20, *Standard for the Installation of Centrifugal Fire Pumps*.

2-4* Tanks.

When gravity, pressure, or suction tanks are to be used, the authority having jurisdiction shall be consulted. Tanks shall be installed in accordance with NFPA 22, *Standard for Water Tanks for Private Fire Protection*.

2-5 Penstocks or Flumes, Rivers, or Lakes.

Water supply connections from penstocks, flumes, rivers, lakes, or reservoirs shall be arranged to avoid mud and sediment and shall be provided with approved double removable screens or approved strainers installed in an approved manner.

2-6* Fire Department Connections.

2-6.1

A connection through which the public fire department can pump water into the sprinkler, standpipe, or other system furnishing water for fire extinguishment can make a desirable auxiliary supply. For this purpose, one or more fire department connections shall be provided.

Exception: Omission of fire department connections shall be permitted when approved by the authority having jurisdiction.

2-6.2

Fire department connections shall be properly supported.

2-6.3

There shall be no shutoff valve in the fire department connection.

2-6.4

An approved straightway check valve shall be installed in each fire department connection, located as near as practicable to the point where it joins the system.

2-6.5

The pipe between the check valve and the outside hose coupling shall be equipped with an approved automatic drip, arranged to discharge to a proper place.

2-6.6

Fire department connections shall be of an approved type.

2-6.7

The fire department connection(s) shall have the NH internal threaded swivel fitting(s) having the NH standard thread, at least one of which shall be the 2.5-7.5 NH standard thread, as specified in NFPA 1963, *Standard for Fire Hose Connections*.

Exception: Where local fire department connections do not conform to NFPA 1963,

Standard for Fire Hose Connections, the authority having jurisdiction shall designate the connection to be used.

2-6.8

Fire department connections shall be equipped with standard caps, properly secured and arranged for easy removal by fire departments.

2-6.9

Fire department connections shall be on the street side of buildings and shall be located and arranged so that hose lines can be readily and conveniently attached to the inlets without interference from any nearby objects including buildings, fences, posts, or other fire department connections.

2-6.10 Signs.

2-6.10.1

Fire department connections shall be designated by a sign having raised letters at least 1 in. (25.4 mm) in size cast on a plate or fitting, reading for service designated: i.e., "AUTO SPKR." or "OPEN SPKR." or "STANDPIPE," etc.

2-6.10.2

Where a fire department connection only supplies a portion of the building, a sign shall be attached indicating the portions of the building supplied.

Chapter 3 Valves

3-1 Types of Valves.

3-1.1

All control valves shall be listed indicating type valves.

Exception: When acceptable to the authority having jurisdiction, listed non-indicating valves with approved roadway boxes shall be permitted and a T-wrench shall be provided in a clearly identified and readily accessible location on the premises.

Water control valves shall not close in less than 5 seconds when operated at maximum possible speed from the full open position to avoid damage to piping by water hammer.

The following shall not be required to incorporate indicating devices as part of the valve. The valve assemblies shall qualify as an indicating valve.

- (a) A listed control valve equipped with a listed indicating device.
- (b) A listed control valve that has a reliable position indication connected to a remote supervisory station.

3-1.2

Check valves shall be listed.

3-2 Valves Controlling Water Supplies.

3-2.1

At least one control valve shall be installed in each source of water supply except fire department connections.

3-2.2

Where there is more than one source of water supply, a check valve shall be installed in each connection.

Exception: Where cushion tanks are used with automatic fire pumps, no check valve is required in the cushion tank connection.

3-2.3*

A control valve shall be installed on each side of each check valve.

Exception: In the discharge pipe from a pressure tank or a gravity tank of less than 15,000 gal (56.78 m³) capacity, no control valve need be installed on the tank side of the check valve.

3-2.4*

Where a gravity tank is located on a tower in the yard, the control valve on the tank side of the check valve shall be an outside screw and yoke or listed indicating valve; the other shall be either an outside screw and yoke, listed indicating valve, or a listed valve having a post-type indicator. Where a gravity tank is located on a building, both control valves shall be outside screw and yoke or listed indicating valves, and all fittings inside the building, except the drain tee and heater connections, shall be under the control of a listed valve.

3-2.5*

When a pump is located in a combustible pump house or exposed to danger from fire or falling walls, or when a tank discharges into a private fire service main fed by another supply, either the check valve in the connection shall be located in a pit or the control valve shall be of the post indicator type located a safe distance outside buildings.

3-2.6*

All control valves shall be located where readily accessible and free of obstructions.

3-3 Post Indicator Valves.

3-3.1*

Every connection from the private fire service main to a building shall be provided with a listed post indicating valve located so as to control all sources of water supply, except fire department connections, when arranged as specified in Section 2-6.

Exception: Omission of the post indicator valve shall be permitted by the authority having jurisdiction in accordance with the provisions of 3-1.1 and 3-4.1.

3-3.2

Post indicator valves shall be located not less than 40 ft (12.2 m) from buildings.

Exception: When post indicator valves cannot be placed at this distance, they shall be permitted to be located closer, or wall post indicator valves used, provided they are set in locations by blank walls where the possibility of injury by falling walls is unlikely and from which people are not likely to be driven by smoke or heat. Usually, in crowded plant yards, they can be placed beside low buildings, near brick stair towers, or at angles formed by substantial brick walls that are not likely to fall.

3-3.3

Post indicator valves shall be set so that the top of the post will be 36 in. (0.9 m) above the final grade.

3-3.4

Post indicator valves shall be properly protected against mechanical damage where needed.

3-4 Valves in Pits.

3-4.1

Where it is impractical to provide a post indicator valve, valves shall be permitted to be placed in pits with permission of the authority having jurisdiction.

3-4.2*

When used, valve pits shall be of adequate size and readily accessible for inspection, operation, testing, maintenance, and removal of equipment contained therein. They shall be constructed and arranged to properly protect the installed equipment from movement of earth, freezing, and accumulation of water. Poured-in-place or precast concrete, with or without reinforcement, or brick (all depending upon soil conditions and size of pit) are appropriate materials for construction of valve pits. Other approved materials shall be permitted to be used. Where the water table is low and the soil is porous, crushed stone or gravel shall be permitted to be used for the floor of the pit. See Figure A-2-6(b) for a suggested arrangement.

Valve pits located at or near the base of the riser of an elevated tank shall be designed in accordance with Chapter 9 of NFPA 22, *Standard for Water Tanks for Private Fire Protection*.

3-4.3

The location of the valve shall be clearly marked, and the cover of the pit shall be kept free of obstructions.

3-5 Sectional Valves.

3-5.1

Large private fire service main systems shall have sectional controlling valves at appropriate points in order to permit sectionalizing the system in the event of a break, or for the making of repairs or extensions.

3-5.2

A valve shall be provided on each bank where a main crosses water, and outside the building foundation(s) where the main or section of main runs under a building. (See 8-3.1.)

3-6 Identifying and Securing.

3-6.1

Identification signs shall be provided at each valve to indicate its function and what it controls.

3-6.2*

Valves on connections to water supplies, sectional control and isolation valves, and other valves in supply piping to sprinkler and other fixed water-based fire suppression systems and hydrants shall be supervised in the normal position by one of the following methods:

- (a) Central station proprietary or remote station signaling electrical supervision service,
- (b) Local electrical supervision through use of a signaling service that will cause the sounding of an audible signal at a constantly attended point,
- (c) Locking valves in the correct position with monthly recorded inspections,
- (d) Sealing of valves and approved weekly recorded inspection when valves are located within fenced enclosures under the control of the owner.

Exception: Underground gate valves with roadway boxes need not be supervised.

Chapter 4 Hydrants

4-1* General.

4-1.1

Hydrants shall be of approved type and have not less than a 6-in. (152-mm) diameter connection with the mains. A valve shall be installed in the hydrant connection. The number, size, and arrangement of outlets, the size of the main valve opening, and the size of the barrel shall be suitable for the protection to be provided and shall be approved by the authority having jurisdiction. Independent gate valves on 2½-in. (64-mm) outlets are permitted. (See Chapter 5.)

4-1.2

Hydrant outlet threads shall have the NH standard external threads for the size outlet(s) supplied as specified in NFPA 1963, *Standard for Fire Hose Connections*.

Exception: Where local fire department connections do not conform to NFPA 1963, Standard for Fire Hose Connections, the authority having jurisdiction shall designate the connection to be used.

4-1.3*

Hydrants on private service mains shall not be equipped with pumper outlets unless the calculated demand for large hose (3.5 in. and larger) is added to the attack hose and sprinkler system demands in determining the total demand on the fire protection water supply.

4-2 Number and Location.

4-2.1*

Hydrants shall be provided in sufficient number and be located in a manner that will enable the needed fire flow to be delivered through hose lines to all exterior sides of any important structure. Hydrants shall be spaced in accordance with the authority having jurisdiction. Public hydrants are recognized as meeting all or part of the above requirements.

4-2.2*

For average conditions, hydrants shall be placed at least 40 ft (12.2 m) from the buildings protected.

Exception: When hydrants cannot be placed at this distance, they shall be permitted to be located closer, or wall hydrants used (see Figure A-4-2.2), provided they are set in locations by blank walls where the possibility of injury by falling walls is unlikely and from which people are not likely to be driven by smoke or heat. Usually, in crowded plant yards, they can be placed beside low buildings, near brick stair towers or at angles formed by substantial brick walls that are not likely to fall.

4-2.3

Hydrants shall not be placed near retaining walls where there is danger of frost through the walls.

4-3 Installation and Maintenance.

4-3.1

Hydrants shall be set on flat stones or concrete slabs and, if necessary, shall be provided with sufficient small stones (or equivalent) placed about the drain to ensure quick drainage.

4-3.2

Where soil is of such a nature that the hydrants will not drain properly with the arrangement

specified in 4-3.1, or ground water stands at levels above that of the drain, the hydrant drain shall be plugged at the time of installation. If the drain is plugged, hydrants in service in cold climates shall be pumped out after usage. Such hydrants shall be marked to indicate the need for pumping out after usage.

4-3.3*

The center of a hose outlet shall be not less than 18 in. (457 mm) above final grade, or when located in a hose house, 12 in. (305 mm) above the floor.

4-3.4

Hydrants shall be fastened to piping by standard clamps or be properly anchored.

4-3.5

Hydrants shall be protected if subject to mechanical damage. The means of protection shall be arranged in a manner that will not interfere with the connection to, or operation of, hydrants.

4-3.6*

To ensure proper functioning, wet barrel hydrants shall be tested at least annually, and dry barrel hydrants tested semiannually in the early spring and fall, in accordance with the requirements of the authority having jurisdiction.

4-3.7

Check valves, detector check valves, back flow prevention valves, and similar appurtenances shall not be installed in the service stub between a fire hydrant and private water supply piping.

Chapter 5 Hose Houses and Equipment

5-1 General.

5-1.1*

An adequate supply of hose and equipment shall be provided when hydrants are intended for use by plant personnel or a fire brigade. The quantity and type of hose and equipment will depend upon the number and location of hydrants relative to the protected property, the extent of the hazard, and the fire-fighting capabilities of the potential users. The authority having jurisdiction shall be consulted.

5-1.2*

Hose shall conform to NFPA 1961, *Standard for Fire Hose*.

5-1.3*

Hose shall be stored so it is readily accessible and is protected from the weather. This can

be done by storing hose in hose houses or by placing hose reels or hose carriers in weatherproof enclosures.

5-1.4 Hose Couplings.

Hose coupling threads shall conform to the NH standard threads, as specified in NFPA 1963, *Standard for Fire Hose Connections*.

Exception: Where local fire department connections do not conform to NFPA 1963, Standard for Fire Hose Connections, the authority having jurisdiction shall designate the connections to be used.

5-2 Location.

5-2.1

When hose houses are utilized, they shall be located over the hydrant or immediately nearby. Hydrants within hose houses shall be as close to the front of the house as possible and still allow sufficient room back of the doors for the hose gates and the attached hose.

5-2.2

When hose reels or hose carriers are utilized, they shall be located so that the hose can be brought quickly into use at a hydrant. For equipment details when utilizing hose reels and hose carriers, see 5-1.4 and Section 5-6.

5-3 Construction.

Hose houses shall be of substantial construction on adequate foundations. The construction shall be such as to protect the hose from weather and vermin, and designed so that hose lines can be quickly brought into use. Clearance shall be provided for proper operation of the hydrant wrench. Proper ventilation shall be provided. The exterior shall be painted or otherwise suitably protected against deterioration.

5-4* Size and Arrangement.

Hose houses shall be of a size and arrangement to provide shelves or racks for the hose and equipment. (*For equipment details of hose houses, see Section 5-6 and 5-1.4.*)

5-5 Marking.

Hose houses shall be plainly identified.

5-6 Equipment—General.

5-6.1*

When hose houses are used in addition to the hose, each shall be equipped with:

2 approved adjustable spray-solid stream nozzles equipped with shutoffs for each size of hose provided

1 hydrant wrench (in addition to wrench on hydrant)

4 coupling spanners for each size hose provided

2 hose coupling gaskets for each size hose.

5-6.1.1

Where two sizes of hose and nozzles are provided, reducers or gated wyes shall be included in the hose house equipment.

5-7 Domestic Service Use Prohibited.

The use of hydrants and hose for purposes other than fire-related services shall be prohibited.

Chapter 6 Master Streams

6-1* General.

Master streams are delivered by monitor nozzles, hydrant-mounted monitor nozzles, or portable deluge sets capable of delivering more than 250 gpm (946 L/min).

6-2 Application.

Master streams shall be provided as protection for large amounts of combustible materials located in yards, average amounts of combustible materials in inaccessible locations, or occupancies presenting special hazards as required by the authority having jurisdiction.

6-3 Special Consideration.

The location of this apparatus, the size of piping supplying it, the arrangement of control valves, and the necessary water supplies all demand special considerations in each individual case, and the authority having jurisdiction shall be consulted.

Chapter 7* Pipe and Fittings

7-1* Selection of Pipe.

7-1.1*

Piping shall be listed for fire protection service and comply with AWWA standards, where applicable. Steel piping shall not be allowed for use in private fire service main applications.

Exception: Approved steel piping shall be permitted for use in fire protection service applications where located aboveground and approved by the authority having jurisdiction.

7-1.2*

The type and class of pipe for a particular installation shall be determined through consideration of its fire resistance, the maximum working pressure, the laying conditions under which the pipe is to be installed, soil conditions, corrosion, and susceptibility of pipe

to other external loads, including earth loads installation beneath buildings and traffic or vehicle loads.

7-1.3

Pipe used in private fire service shall be designed to withstand a working pressure of not less than 150 psi (10.3 bars).

7-1.4*

For purposes of estimating friction loss, see A-7-1.4.

7-2* Coating and Lining of Buried Pipe.

All ferrous metal pipe shall be lined and, additionally, steel pipe shall be coated and wrapped. For buried pipe, galvanizing, internally or externally, does not meet the requirements of this section.

Exception: Internal galvanizing shall be permitted as the lining for the pipe between the check valve and the outside hose coupling for the fire department connection.

7-3* Buried Joints.

Joints shall be of an approved type. Steel pipe joints shall be field-coated and wrapped after assembly.

7-4* Buried Fittings.

Fittings shall be of an approved type with joints and pressure class ratings compatible with the pipe used. Steel pipe fittings shall be coated, wrapped, and lined.

7-5 Aboveground Pipe and Fittings.

7-5.1

Aboveground pipe and fittings shall comply with the applicable sections of Chapters 2 and 4 of NFPA 13, *Standard for the Installation of Sprinkler Systems*, addressing pipe, fittings, joining methods, hangers, and installation.

7-5.2 Protection of Piping.

7-5.2.1

Aboveground piping shall not pass through hazardous areas and shall be located so that it is protected from mechanical and fire damage.

Exception: Aboveground piping is permitted to be located in hazardous areas protected by an automatic sprinkler system.

7-5.2.2

Where aboveground piping passes through an area subject to freezing temperatures, it shall

be protected by a reliable means to maintain the temperature of the water in the piping between 40°F (4.4°C) and 120°F (48.9°C).

7-5.2.3

Where corrosive conditions exist or piping is exposed to the weather, corrosion-resistant types of pipe, fittings, and hangers or protective corrosion-resistant coatings shall be used.

7-5.2.4

To minimize or prevent pipe breakage where subject to earthquakes, aboveground pipe shall be protected in accordance with NFPA 13, *Standard for the Installation of Sprinkler Systems*.

7-5.2.5

Mains that pass through walls, floors, and ceilings shall be provided with adequate clearances in accordance with NFPA 13, *Standard for the Installation of Sprinkler Systems*.

7-6 Sizes of Aboveground and Buried Pipe.

7-6.1

No pipe smaller than 6 in. (152 mm) in diameter shall be installed as a private service main.

Exception: For mains that do not supply hydrants, sizes smaller than 6 in. (152 mm) shall be permitted to be used subject to the following restrictions:

(a) *The main supplies only automatic sprinkler systems, open sprinkler systems, water spray fixed systems, foam systems, or Class II standpipe systems.*

(b) *Hydraulic calculations show that the main will supply the total demand at the appropriate pressure. Systems that are not hydraulically calculated shall have a main at least as large as the riser.*

7-6.2

The size of the private fire service mains supplying fire protection systems shall be approved by the authority having jurisdiction, due consideration being given to the construction and occupancy of the plant, to the fire flow and pressure of water required, and to the adequacy of the supply.

Chapter 8* Rules for Laying Buried Pipe

8-1 Depth of Cover.

8-1.1*

The depth of cover over water pipes shall be determined by the maximum depth of frost penetration in the locality where the pipe is laid. The top of the pipe shall be buried not less than 1 ft (0.3 m) below the frost line for the locality. In those locations where frost is not a

factor, the depth of cover shall be not less than 2¹/₂ ft (0.8 m) to prevent mechanical damage. Pipe under driveways shall be buried a minimum of 3 ft (0.9 m) and under railroad tracks a minimum of 4 ft (1.2 m).

8-1.2

Depth of covering shall be measured from top of pipe to finished grade, and due consideration shall always be given to future or final grade and nature of soil.

8-2 Protection Against Freezing.

8-2.1

Where it is impracticable to bury pipe, it shall be permitted to be laid aboveground, provided the pipe is protected against freezing and mechanical damage, to the satisfaction of the authority having jurisdiction.

8-2.2

Pipes shall not be placed over water raceways or near embankment walls without special attention being given to protection against frost.

8-2.3

Where pipe is laid in water raceways or shallow streams, care shall be taken that there will be sufficient depth of running water between the pipe and the frost line during all seasons of frost; a safer method is to bury the pipe 1 ft (0.3048 m) or more under the bed of the waterway. Care shall also be taken to keep the pipe back from the banks a sufficient distance to avoid any danger of freezing through the side of the bank above the water line. Pipe shall be buried below the frost line where entering the water.

8-3 Protection Against Damage.

8-3.1

Pipe shall not be run under buildings.

Exception: When absolutely necessary to run pipe under buildings, special precautions shall be taken which include arching the foundation walls over the pipe, running pipe in covered trenches, and providing valves to isolate sections of pipe under buildings. (See 3-5.2.)

8-3.2

Where a riser is close to building foundations, underground fittings of proper design and type shall be used to avoid pipe joints being located in or under the foundations.

8-3.3

Mains running under railroads carrying heavy trucking, under large piles of heavy commodities, or in areas subjecting the main to heavy shock and vibrations shall be

subjected to an evaluation of the specific loading conditions and suitably protected, if necessary. (See 7-1.2.)

8-3.4*

When it is necessary to join metal pipe with pipe of dissimilar metal, the joint shall be insulated, by an approved method, against the passage of an electric current.

8-3.5

In no case shall the pipe be used for grounding of electrical services.

8-4 Care in Laying.

8-4.1

Pipes, valves, hydrants, and fittings shall be inspected for damage when received and shall be inspected prior to installation. Bolted joints shall be checked for proper torquing of bolts. Pipe, valves, hydrants, and fittings shall be clean inside. When work is stopped, open ends shall be plugged to prevent stones and foreign materials from entering.

8-4.2

All pipe, fittings, valves, and hydrants shall be carefully lowered into the trench with suitable equipment. They shall be carefully examined for cracks or other defects while suspended above the trench immediately before installation. Plain ends shall be inspected with special attention, as these ends are the most susceptible to damage. Under no circumstances shall water main materials be dropped or dumped. Pipe shall not be rolled or skidded against other pipe materials.

8-4.3

Pipes shall bear throughout their full length and shall not be supported by the bell ends only or by blocks.

Exception: If ground is soft, or of a quicksand nature, special provisions shall be made for supporting pipe. For ordinary conditions of soft ground, longitudinal wooden stringers with cross ties will give good results.

8-4.4

Valves and fittings used with nonmetallic pipe shall be properly supported and restrained in accordance with the manufacturer's specifications.

8-5 Pipe Joint Assembly.

8-5.1

Joints shall be assembled by persons familiar with the particular materials being used and in accordance with the manufacturer's instructions and specifications.

8-5.2

All bolted joint accessories shall be cleaned and thoroughly coated with asphalt or other corrosion-retarding material after installation.

8-6 Restraining Fire Mains.

8-6.1*

All tees, plugs, caps, bends, and hydrant branches shall be restrained against movement.

8-6.2* Methods of Restraining Fire Mains.

8-6.2.1*

Thrust blocks are satisfactory where soil is suitable. The thrust blocks shall be of a concrete mix not leaner than one part cement, two and one-half parts sand, and five parts stone. Thrust blocks shall be placed between undisturbed earth and the fitting to be restrained, and shall be of such bearing as to ensure adequate resistance to the thrust to be encountered. In general, thrust blocks shall be so placed that the joints will be accessible for inspection and repair.

8-6.2.2

Pipe clamps and tie-rods, thrust blocks, locked mechanical or push-on joints, mechanical joints utilizing set screw retainer glands, or other approved methods or devices shall be used. The type of pipe, soil conditions, and available space determine the method.

8-6.2.3 Sizing the Clamps, Rods, Bolts, and Washers.

(a) Clamps shall be; $\frac{1}{2}$ in. \times 2 in. (12.7 mm \times 50.8 mm) for pipe 4 in. to 6 in.; $\frac{5}{8}$ in. \times 2 $\frac{1}{2}$ in. (15.9 mm \times 63.5 mm) for pipe 8 in. to 10 in.; $\frac{5}{8}$ in. \times 3 in. (15.9 mm \times 76.2 mm) for pipe 12 in. Bolt holes shall be $\frac{1}{16}$ in. (1.6 mm) diameter larger than bolts.

(b) Minimum rod size shall be; $\frac{5}{8}$ in. (15.9 mm) diameter. Table 8-6.2.3 gives numbers of various diameter rods required for a given pipe size. When using bolting rods, the diameter of mechanical joint bolts limits the size of rods to $\frac{3}{4}$ in. (19.1 mm).

When using clamps, rods shall be used in pairs, two to a clamp.

Exception: Assemblies in which a restraint is made by means of two clamps canted on the barrel of the pipe shall be permitted to use one rod per clamp if approved for the specific installation by the authority having jurisdiction.

When using combinations of rods greater in number than two, the rods shall be symmetrically spaced.

Table 8-6.2.3 Rod Number — Diameter Combinations

Nominal Pipe Size Inches	Number of Rods
--------------------------------	----------------

	$\frac{5}{8}$ in. (15.9 mm)	$\frac{3}{4}$ in. (19.1 mm)	$\frac{7}{8}$ in. (22.2 mm)	1 in. (25.4 mm)
4	2	—	—	—
6	2	—	—	—
8	3	2	—	—
10	4	3	2	—
12	6	4	3	2
14	8	5	4	3
16	10	7	5	4

Table has been derived using pressure of 225 psi (15.5 bars) and design stress of 25,000 psi (172.4 MPa).

(c) Clamp bolts shall be $\frac{5}{8}$ in. (15.9 mm) diameter for pipe 4 in., 6 in., and 8 in.; $\frac{3}{4}$ in. (19.1 mm) diameter for pipe 10 in.; and $\frac{7}{8}$ in. (22.2 mm) diameter for pipe 12 in.

(d) Washers can be cast iron or steel, round or square. Dimensions for cast-iron washers shall be $\frac{5}{8}$ in. \times 3 in. (15.9 mm \times 76.2 mm) for pipe 4 in., 6 in., 8 in., and 10 in.; and $\frac{3}{4}$ in. \times $3\frac{1}{2}$ in. (19.1 mm \times 88.9 mm) for pipe 12 in. Dimensions for steel washers shall be $\frac{1}{2}$ in. \times 3 in. (12.7 mm \times 76.2 mm) for pipe 4 in., 6 in., 8 in., and 10 in.; and $\frac{1}{2}$ in. \times $3\frac{1}{2}$ in. (12.7 mm \times 88.9 mm) for 12 in. Holes shall be $\frac{1}{8}$ in. (3.2 mm) larger than rods.

8-6.2.4 Sizes of Restraint Straps for Tees.

Straps shall be $\frac{5}{8}$ in. (15.9 mm) thick and $2\frac{1}{2}$ in. (63.5 mm) wide for pipe 4 in., 6 in., 8 in., and 10 in.; $\frac{5}{8}$ in. (15.9 mm) thick and 3 in. (76.2 mm) wide for pipe 12 in. Rod holes shall be $\frac{1}{16}$ in. (1.6 mm) larger than rods. Dimensions in inches (mm) for straps are suitable either for mechanical or push-on joint tee fittings.

Figure 8-6.2.4 Restraint straps for tees

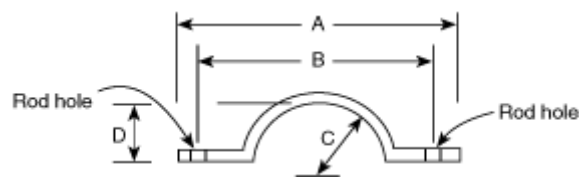

Table 8-6.2.4 Restraint Straps for Tees

	A		B		C		D	
	mm	in.	mm	in.	mm	in.	mm	
$\frac{1}{2}$	318	$10\frac{1}{8}$	257	$2\frac{1}{2}$	64	$1\frac{3}{4}$	44	
$\frac{1}{2}$	368	$12\frac{1}{8}$	308	$3\frac{9}{16}$	90	$2\frac{13}{16}$	71	
$\frac{3}{4}$	425	$14\frac{3}{8}$	365	$4\frac{21}{32}$	118	$3\frac{29}{32}$	99	
$\frac{1}{16}$	484	$16\frac{11}{16}$	424	$5\frac{3}{4}$	146	5	127	
$\frac{1}{16}$	567	$19\frac{3}{16}$	487	$6\frac{3}{4}$	171	$5\frac{7}{8}$	149	

8-6.2.5 Sizes of Plug Strap for Bell End of Pipe.

Strap shall be $\frac{3}{4}$ in. (19.1 mm) thick, $2\frac{1}{2}$ in. (63.5 mm) wide. Strap length is the same as dimension A for tee straps given in Figure 8-6.2.4; distance between centers of rod holes is the same as dimension B for tee straps.

8-6.2.6

Threaded sections of rod shall not be formed or bent.

8-6.2.7

Material used for clamps, rods, rod couplings or turnbuckles, bolts, washers, restraint straps, and plug straps shall be of material having physical and chemical characteristics such that its deterioration under stress can be predicted with reliability.

8-6.2.8*

After installation, rods, nuts, bolts, washers, clamps, and other restraining devices, except thrust blocks, shall be cleaned and thoroughly coated with a bituminous or other acceptable corrosion-retarding material.

8-6.2.9

On steep grades, mains shall be properly restrained to prevent slipping. The pipe shall be restrained at the bottom of a hill and at any turns (lateral or vertical). The restraining shall be done either to natural rock or by means of suitable piers built on the downhill side of the bell. Bell ends shall be installed facing uphill. Straight runs on hills shall be restrained as determined by the design engineer.

8-7 Backfilling.

8-7.1

Backfill shall be well tamped in layers under and around pipes (and puddled where possible) to prevent settlement or lateral movement, and shall contain no ashes, cinders, refuse, organic matter, or other corrosive materials.

8-7.2

Rocks shall not be placed in trenches. Frozen earth shall not be used for backfilling.

8-7.3

In trenches cut through rock, tamped backfill shall be used for at least 6 in. (152 mm) under and around the pipe and for at least 2 ft (0.6 m) above the pipe.

Chapter 9 Flushing and Testing

9-1 Flushing of Piping.

9-1.1

Private fire service mains and lead-in connections to system risers shall be flushed thoroughly before connection is made to system piping in order to remove foreign materials that might have entered the main during the course of the installation or that might have been present in existing piping. The minimum rate of flow shall be not less than the water demand rate of the system, which is determined by the system design, or not less than that necessary to provide a velocity of 10 ft/s (3 m/s), whichever is greater. For all systems, the flushing operations shall be continued for a sufficient time to ensure thorough cleaning. When planning the flushing operations, consideration shall be given to disposal of the water issuing from the test outlets.

Exception: When the flow rate as listed in Table 9-1.1 cannot be verified or met, supply piping shall be flushed at the maximum flow rate available to the system under fire conditions.

Table 9-1.1 Flow Required to Produce a Velocity of 10 Ft per Second (3 m/s) in Pipes

Nominal Pipe Size (in.)	Flow Rate	
	(gpm)	(L/min.)
4	390	1476
6	880	3331
8	1560	5905
10	2440	9235
12	3520	13323

9-2 Testing of Piping.

9-2.1*

Before asking final approval of an installation by the authority having jurisdiction, the installing company shall furnish a Contractor's Material and Test Certificate countersigned by the property owner or representative.

A typical certificate is shown in Figure A-9-2.1.

9-2.2*

The trench shall be backfilled between joints before testing to prevent movement of pipe. (See A-9-2.2.)

9-2.3 Hydrostatic Test Requirements.

9-2.3.1*

All new private fire service mains shall be tested hydrostatically at not less than 200 psi (13.8 bars) pressure for two hours, or at 50 psi (3.4 bars) in excess of the maximum static pressure when the maximum static pressure is in excess of 150 psi (10.3 bars). (See A-9-

2.3.1.)

9-2.3.2*

The amount of leakage in buried piping shall be measured at the specified test pressure by pumping from a calibrated container. For new pipe, the amount of leakage at the joints shall not exceed two quarts per hour (1.89 L/h) per 100 gaskets or joints irrespective of pipe diameter. No visible leakage shall be allowed in aboveground piping.

9-2.3.3*

The amount of allowable leakage specified in 9-2.3.2 shall be permitted to be increased by one fluid ounce per inch valve diameter per hour (30 ml/25 mm/h) for each metal seated valve isolating the test section. If dry barrel hydrants are tested with the main valve open, so the hydrants are under pressure, an additional five ounces per minute (150 ml/min) leakage is permitted for each hydrant.

9-2.3.4

Tests shall be made by the contractor in the presence of the authority having jurisdiction or the representative of the owner. The certificate shown in Figure A-9-2.1 is to be completed.

9-2.3.5 Additives.

Additives, corrosive chemicals such as sodium silicate, brine, or other chemicals shall not be used while hydrostatically testing systems or for stopping leaks.

9-2.4 Operating Test.

9-2.4.1

Each hydrant shall be fully opened and closed under system water pressure and dry barrel hydrants checked for proper drainage. Where fire pumps are available, this shall be done with the pumps running.

9-2.4.2

All control valves shall be fully closed and opened under system water pressure to ensure proper operation.

Chapter 10 Referenced Publications

10-1

The following documents or portions thereof are referenced within this standard and shall be considered part of the requirements of this document. The edition indicated for each reference is the current edition as of the date of the NFPA issuance of this document.

10-1.1 NFPA Publications.

National Fire Protection Association, 1 Batterymarch Park, P.O. Box 9101, Quincy, MA

Copyright NFPA

02269-9101.

NFPA 13, *Standard for the Installation of Sprinkler Systems*, 1994 edition.

NFPA 20, *Standard for the Installation of Centrifugal Fire Pumps*, 1993 edition.

NFPA 22, *Standard for Water Tanks for Private Fire Protection*, 1993 edition.

NFPA 1961, *Standard for Fire Hose*, 1992 edition.

NFPA 1963, *Standard for Fire Hose Connections*, 1993 edition.

10-1.2 AWWA Publications.

American Water Works Association, Inc., 666 West Quincy Avenue, Denver, CO 80235.

AWWA C104, *Cement Mortar Lining for Ductile Iron Pipe and Fittings for Water*, 1990.

AWWA C105, *Polyethylene Encasement for Ductile Iron Piping for Water and Other Liquids*, 1993.

AWWA C110, *Ductile Iron and Gray Iron Fittings, 3-in. Through 48-in., for Water and Other Liquids*, 1993.

AWWA C111, *Rubber-Gasket Joints for Ductile Iron Pressure Pipe and Fittings*, 1990.

AWWA C115, *Standard for Flanged Ductile Iron Pipe with Threaded Flanges*, 1988.

AWWA C150, *Thickness Design of Ductile Iron Pipe*, 1991.

AWWA C151, *Ductile Iron Pipe, Centrifugally Cast in Metal Molds or Sand-Lined Molds, for Water or Other Liquids*, 1991.

AWWA C200, *Steel Water Pipe 6 in. and Larger*, 1991.

AWWA C203, *Coal-Tar Protective Coatings and Linings for Steel Water Pipelines Enamel and Tape — Hot Applied*, 1991.

AWWA C205, *Cement-Mortar Protective Lining and Coating for Steel Water Pipe 4 in. and Larger — Shop Applied*, 1989.

AWWA C206, *Standard for Field Welding of Steel Water Pipe*, 1991.

AWWA C207, *Standard for Steel Pipe Flanges for Waterworks Service — Sizes 4 in. Through 144 in.*, 1986.

AWWA C208, *Dimensions for Fabricated Steel Water Pipe Fittings*, 1983.

AWWA C300, *Reinforced Concrete Pressure Pipe, Steel Cylinder Type for Water and Other Liquids*, 1989.

AWWA C301, *Prestressed Concrete Pressure Pipe, Steel-Cylinder Type, for Water and Other Liquids*, 1992.

AWWA C302, *Reinforced Concrete Pressure Pipe, Non-Cylinder Type, for Water and Other Liquids*, 1987.

AWWA C303, *Reinforced Concrete Pressure Pipe, Steel-Cylinder Type, Pretensioned, for*

Water and Other Liquids, 1987.

AWWA C400, *Standard for Asbestos-Cement Distribution Pipe, 4 in. Through 16 in., for Water and Other Liquids*, 1993.

AWWA C401, *Standard Practice for the Selection of Asbestos-Cement Water Pipe*, 1993.

AWWA C600, *Standard for the Installation of Ductile Iron Water Mains and Their Appurtenances*, 1993.

AWWA C602, *Cement-Mortar Lining of Water Pipe Lines 4 in. and Larger in Place*, 1989.

AWWA C603, *Installation of Asbestos-Cement Pressure Pipe*, 1990.

AWWA C900, *Polyvinyl Chloride (PVC) Pressure Pipe, 4 in. Through 12 in., for Water Distribution*, 1989.

AWWA M11, *Steel Pipe — A Guide for Design and Installation*, 1989.

10-1.3 ANSI Publication.

American National Standards Institute, 1430 Broadway, New York, NY 10018.

ANSI B16.1, *Standard for Cast-Iron Pipe Flanges and Flanged Fittings for 25, 125, 250 and 800 lb*, 1975.

Appendix A Explanatory Material

Appendix A is not a part of the requirements of this NFPA document but is included for informational purposes only. This appendix contains explanatory material, numbered to correspond with the applicable text paragraphs.

A-1-3 Approved.

The National Fire Protection Association does not approve, inspect, or certify any installations, procedures, equipment, or materials; nor does it approve or evaluate testing laboratories. In determining the acceptability of installations, procedures, equipment, or materials, the authority having jurisdiction may base acceptance on compliance with NFPA or other appropriate standards. In the absence of such standards, said authority may require evidence of proper installation, procedure, or use. The authority having jurisdiction may also refer to the listings or labeling practices of an organization concerned with product evaluations that is in a position to determine compliance with appropriate standards for the current production of listed items.

A-1-3 Authority Having Jurisdiction.

The phrase “authority having jurisdiction” is used in NFPA documents in a broad manner, since jurisdictions and approval agencies vary, as do their responsibilities. Where public safety is primary, the authority having jurisdiction may be a federal, state, local, or other regional department or individual such as a fire chief; fire marshal; chief of a fire prevention bureau, labor department, or health department; building official; electrical inspector; or others having statutory authority. For insurance purposes, an insurance inspection department, rating bureau, or other insurance company representative may be the

authority having jurisdiction. In many circumstances, the property owner or his or her designated agent assumes the role of the authority having jurisdiction; at government installations, the commanding officer or departmental official may be the authority having jurisdiction.

A-1-3 Listed.

The means for identifying listed equipment may vary for each organization concerned with product evaluation, some of which do not recognize equipment as listed unless it is also labeled. The authority having jurisdiction should utilize the system employed by the listing organization to identify a listed product.

Figure A-1-3 Typical private fire service main

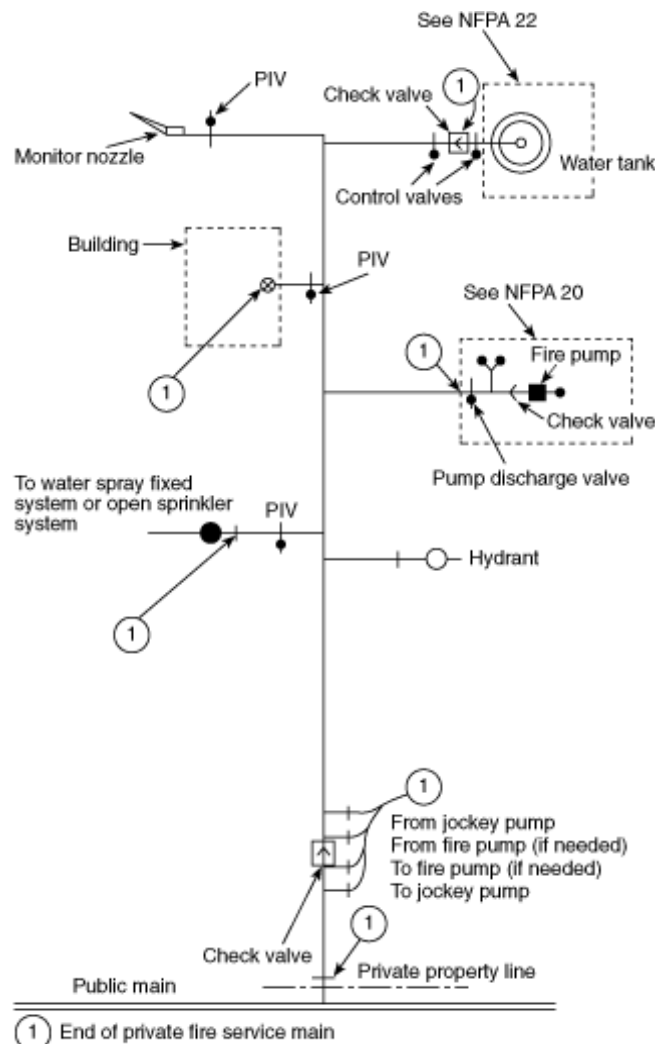

NOTE: The piping (aboveground or buried) shown is specific as to the end of the private fire service main and schematic only for illustrative purposes beyond. Details of valves and their location requirements are covered in the specific standard involved.

A-1-4

Piping should be laid so that the system can be extended with a minimum of expense.

Possible future plant expansion should also be considered and the piping laid so that it will not be covered by buildings. One or more framed plans of the complete system (kept corrected up to date) should be conspicuously posted for ready reference.

A-2-2.3

Dead-end mains should be avoided, if possible, by arranging for mains supplied from both directions. When private fire service mains are connected to dead-end public mains, each situation should be examined to determine if it is practical to request the water utility to loop the mains in order to obtain a more reliable supply.

A-2-2.5

Where connections are made from public waterworks systems, such systems should be guarded against possible contamination as follows (*see AWWA Manual 14, Backflow Prevention and Cross Connection Control*):

(a) For private fire service mains with direct connections from public waterworks mains only or with booster pumps installed in the connections from the street mains; no tanks or reservoirs; no physical connection from other water supplies; no anti-freeze or other additives of any kind; and with all drains discharging to atmosphere, dry well, or other safe outlets, no backflow protection is recommended at the service connection.

(b) For private fire service mains with direct connection from the public water supply main plus one or more of the following: elevated storage tanks; fire pumps taking suction from aboveground covered reservoirs or tanks (all storage facilities are filled or connected to public water only, the water in the tanks to be maintained in a potable condition), an approved double check valve assembly is recommended.

(c) For private fire service mains directly supplied from public mains with an auxiliary water supply such as a pond or river on or available to the premises and dedicated to fire department use; or for systems supplied from public mains and interconnected with auxiliary supplies, such as: pumps taking suction from reservoirs exposed to contamination or rivers and ponds; driven wells, mills, or other industrial water systems; or for systems or portions of systems where anti-freeze or other solutions are used, an approved reduced-pressure-zone-type backflow preventer is recommended.

A-2-3

See sections dealing with sprinkler equipment supervisory and water flow alarm services in NFPA 72, *National Fire Alarm Code*. See separately published NFPA 13, *Standard for the Installation of Sprinkler Systems*, and NFPA 20, *Standard for the Installation of Centrifugal Fire Pumps*.

A-2-4

See NFPA 22, *Standard for Water Tanks for Private Fire Protection*, when gravity, pressure, or suction tanks are to be used.

A-2-6

Typical fire department connections are shown in Figures A-2-6(a) and A-2-6(b). See

NFPA 13E, *Guide for Fire Department Operations in Properties Protected by Sprinkler and Standpipe Systems.*

Figure A-2-6(a) Fire department connection

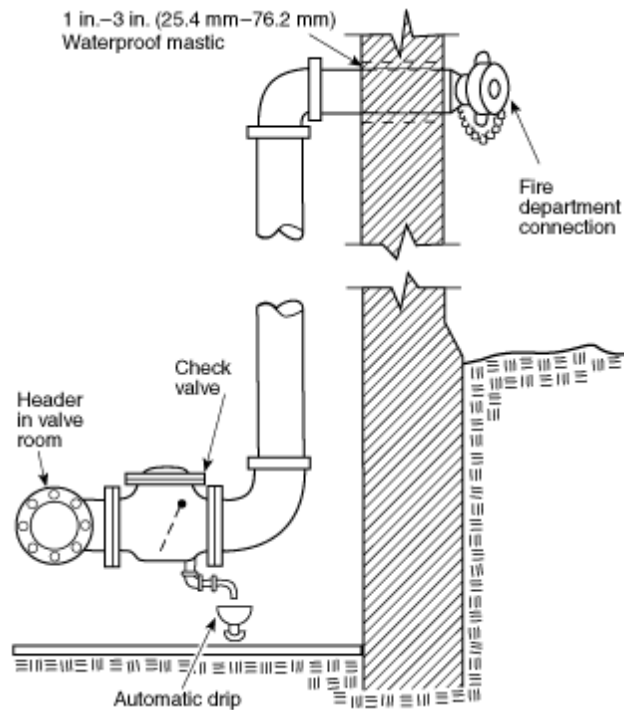
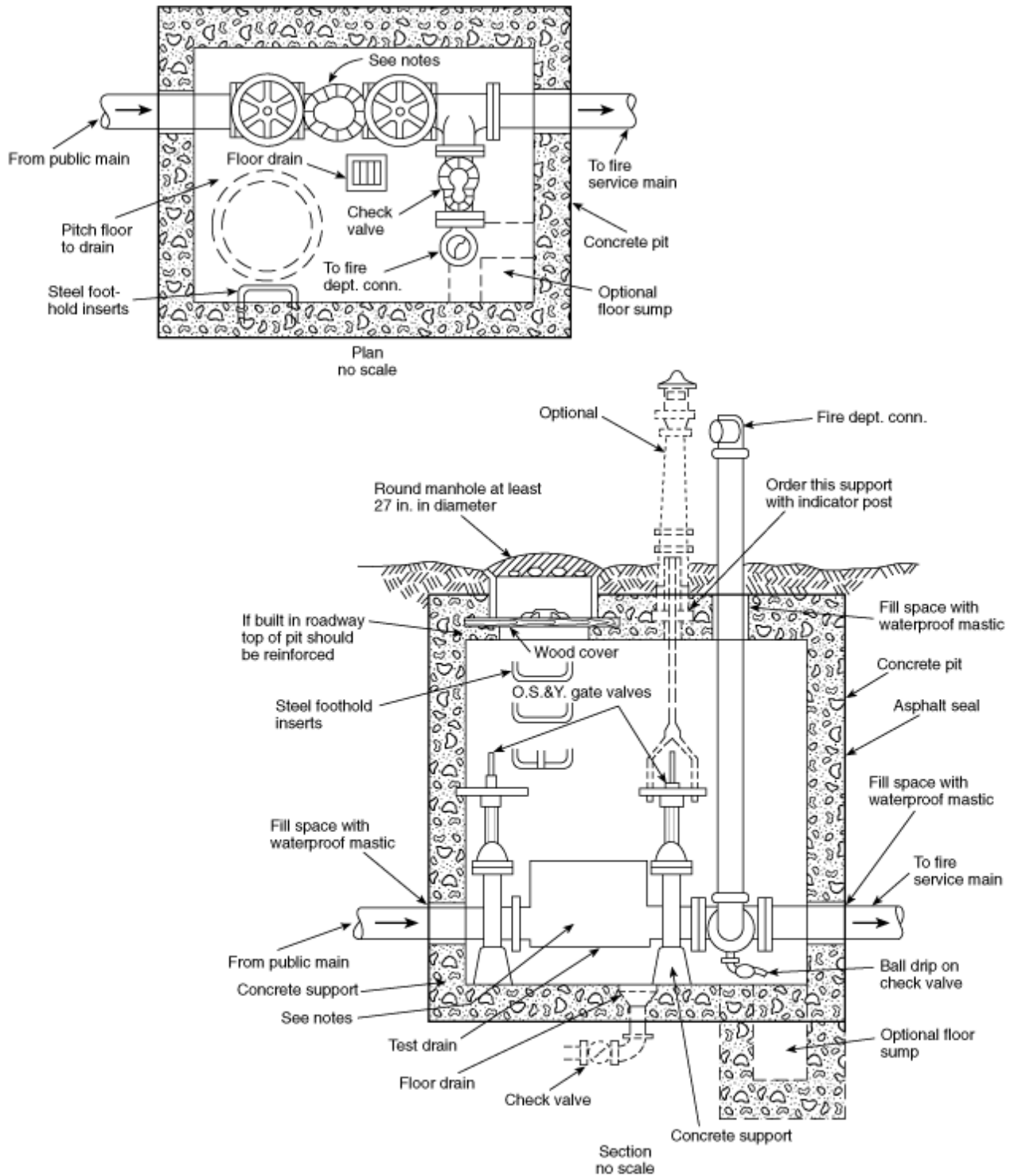

Figure A-2-6(b) Typical city water pit — valve arrangement



Notes to Figure A-2-6(b)

1. Various backflow prevention regulations accept different devices at the connection between public water mains and private fire service mains.
2. The device shown in the pit could be any or a combination of the following:

(a) Gravity check valve	(d) Reduced pressure zone (RPZ) device
(b) Detector check valve	(e) Vacuum breaker
(c) Double check valve assembly	
3. Some backflow prevention regulations prohibit these devices from being installed in a pit.
4. In all cases, the device(s) in the pit should be approved or listed as necessary. The requirements of the local or municipal water department should be reviewed prior to design or installation of the connection.
5. Pressure drop should be considered prior to the installation of any backflow prevention devices.

A-3.2.3, A-3-2.4

For additional information on controlling valves, see NFPA 22, *Standard for Water Tanks for Private Fire Protection*.

A-3-2.5

Check valves on tank or pump connections, when located underground, may be placed inside of buildings and at a safe distance from the tank riser or pump, except in cases where the building is entirely of one fire area, when it is ordinarily considered satisfactory to locate the check valve overhead in the lowest level.

A-3-2.6

It might be necessary to provide valves located in pits with an indicator post extending above grade or other means so that the valve can be operated without entering the pit.

A-3-3.1

Outside control valves are suggested in the following order of preference:

- (a) Listed indicating valves at each connection into the building at least 40 ft (12.2 m) from buildings if space permits.
- (b) Control valves installed in a cut-off stair tower or valve room accessible from outside.
- (c) Valves located in risers with indicating posts arranged for outside operation.
- (d) Key operated valves in each connection into the building.

A-3-4.2

A valve wrench with a long handle should be provided at a convenient location on the premises.

A-3-6.2

The management is responsible for the supervision of valves controlling water supply for fire protection and should exert every effort to see that the valves are maintained in the normally open position. This effort includes special precautions to ensure that protection is promptly restored by completely opening valves that are necessarily closed during repairs or alternations. The precautions apply equally to valves controlling sprinklers and other fixed water-based fire suppression systems, hydrants, tanks, standpipes, pumps, street connections, and sectional valves.

Either one, or a combination of the methods of valve supervision described below is considered essential to ensure that the valves controlling fire protection systems are in the normally open position. The methods described are intended as an aid to the person responsible for developing a systematic method of determining that the valves controlling sprinkler systems and other fire protection devices are open.

Continual vigilance is necessary if valves are to be kept in the open position. Responsible day and night employees should be familiar with the location of all valves and their proper

use.

The authority having jurisdiction should be consulted as to the type of valve supervision required. Contracts for equipment should specify that all details are to be subject to the approval of the authority having jurisdiction.

Central Station Supervisory Service. Central station supervisory service systems involve complete, constant, and automatic supervision of valves by electrically operated devices and circuits continually under test and operating through an approved outside central station, in compliance with NFPA 72, *National Fire Alarm Code*.

NOTE: It is understood that only such portions of NFPA 72, *National Fire Alarm Code* that relate to valve supervision should apply.

Proprietary Supervisory Service Systems. Proprietary supervisory service systems include systems where the operation of a valve produces some form of signal and record at a common point by electrically operated devices and circuits continually under test and operating through a central supervising station at the property protected, all in compliance with the standards for the installation, maintenance, and use of local protective, auxiliary protective, remote station protective, and proprietary signaling systems.

NOTE: It is understood that only portions of the standards that relate to valve supervision should apply.

The standard method of locking, sealing, and tagging valves with the object of preventing, so far as possible, their unnecessary closing; to obtain notification of such closing; and to aid in restoring the valve to normal condition is a satisfactory alternate to valve supervision. The authority having jurisdiction should be consulted as to details for specific cases.

Where electrical supervision is not provided, locks or seals should be provided on all valves and should be of a type acceptable to the authority having jurisdiction.

Seals may be marked to indicate the organization under whose jurisdiction the sealing is conducted. All seals should be attached to the valve in such a manner that the valves cannot be operated without breaking the seals. Seals should be of a character to prevent injury in handling and to prevent reassembly when broken. When seals are used, valves should be inspected weekly. The authority having jurisdiction may require a valve tag to be used in conjunction with the sealing.

A padlock, with a chain where necessary, is especially desirable to prevent unauthorized closing of valves in areas where valves are subject to tampering. When such locks are employed, valves should be inspected monthly.

If valves are locked, any distribution of keys should be restricted to only those directly responsible for the fire protection system. Multiple valves should not be locked together; they should be individually locked.

The individual performing the inspections should determine that each valve is in the normal position, properly locked or sealed, and so note on an appropriate record form while still at the valve. The authority having jurisdiction should be consulted for assistance in preparing a suitable report form for this activity.

Identification signs should be provided at each valve to indicate its function and what it

controls.

The position of the spindle of OS&Y valves or the target on the indicator valves cannot be accepted as conclusive proof that the valve is fully open. The opening of the valve should be followed by a test to determine that the operating parts have functioned properly.

The test consists of opening the main drain valve and permitting free flow of water until the gauge reading becomes stationary. If the pressure drop is excessive for the water supply involved, the cause should be determined immediately and the proper remedies taken. When sectional valves or other special conditions are encountered, other methods of testing should be used.

If it becomes necessary to break a seal for emergency reasons, the valve, following the emergency, should be opened by the person responsible for the fire protection of the plant, or his or her designated representative, and this person should apply a seal at the time of the valve opening. This seal should be maintained in place until such time as the authority having jurisdiction can replace it with one of its own.

Seals or locks should not be applied to valves reopened after closure until such time as the inspection procedure is carried out.

Where water is shut off to the sprinkler or other fixed water-based fire suppression systems, a guard or other qualified person should be placed on duty and required to continuously patrol the affected sections of the premises until such time as protection is restored.

During specific critical situations, a person should be stationed at the valve so that the valve may be reopened promptly if necessary. It is the intent of this section that the person remain within sight of the valve and have no other duties beyond this responsibility. This procedure is considered imperative when fire protection is shut off immediately following a fire.

An inspection of all other fire protection equipment should be made prior to shutting off water in order to make sure it is in operative condition.

In case of changes to fire protection equipment, all possible work should be done in advance of shutting off the water so that final connections can be made quickly and protection restored promptly. Many times it will be found that by careful planning open outlets can be plugged and protection restored on a portion of the equipment while the alterations are being made.

Where changes are being made in underground piping, all possible piping should be laid before shutting off the water for final connections.

Where possible, temporary feed lines, such as temporary piping for reconnection of risers by hose lines, etc., should be used to afford maximum protection.

The plant and public fire department, and other authorities having jurisdiction, should be notified of all impairments to fire protection equipment.

A-4-2.1

Fire department pumpers will normally be required to augment the pressure available from

public hydrants.

A-4-2.2

With use of wall hydrants, the authority having jurisdiction should be consulted regarding the necessary water supply and arrangement of control valves at the point of supply in each individual case. (See Figure A-4-2.2.)

Figure A-4-2.2 Typical wall fire hydrant installation

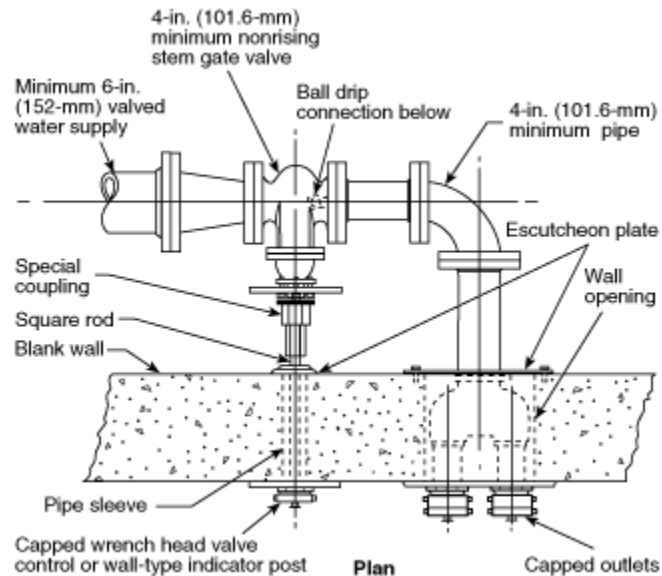

A-4-3.3

In setting hydrants, due regard should be given to final grade line.

Figure A-4-3.3 Typical hydrant connection

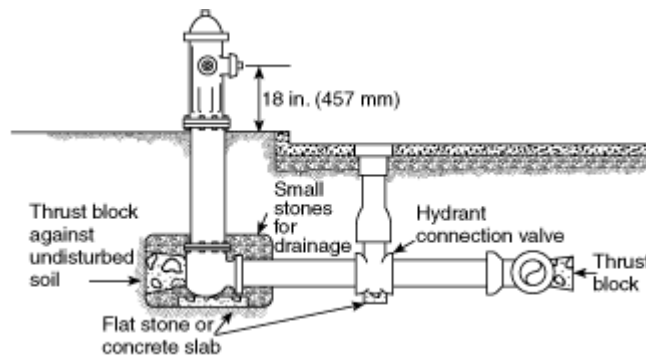

A-4-3.6

See AWWA Manual 17, *Installation, Operation and Maintenance of Fire Hydrants*.

A-5-1.1

All hose should not be removed from a hose house for testing at the same time because the time lost in returning it in case of fire might allow the fire to spread beyond control. See

NFPA 1962, *Standard for the Care, Use, and Service Testing of Fire Hose Including Couplings and Nozzles*.

A-5-1.2

Where hose may be subjected to acids, acid fumes, or other corrosive materials, as in chemical plants, the purchase of approved rubber-covered, rubber-lined hose is advised. For plant yards containing rough surfaces that will cause heavy wear or where working pressures are above 150 psi (10.3 bars), double jacketed hose should be considered.

A-5-1.3

When hose houses are located over hydrants, it is good practice to have two or three lengths of hose connected together and attached to the hydrant ready for use.

A-5-4

Typical hose houses are shown in Figures A-5-4(a) through A-5-4(c).

Figure A-5-4(a) House of five-sided design for installation over a private hydrant



Figure A-5-4(b) Steel house of compact dimensions for installation over a private hydrant. House is shown closed. Top lifts up and doors on front side open for complete accessibility



Figure A-5-4(c) This type of hose house can be installed on legs as illustrated or installed on a wall near, but not directly over, a private hydrant

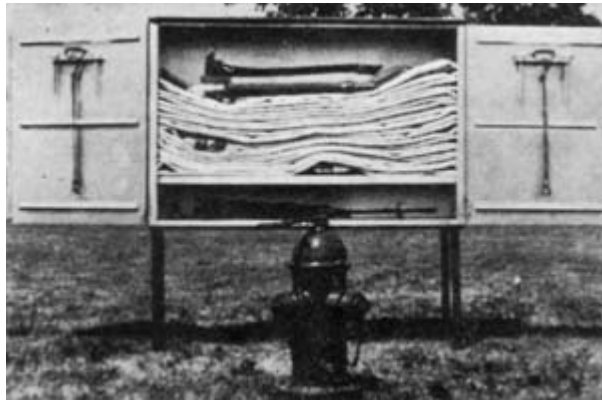

A-5-6.1

Desirable optional equipment to be included in hose house equipment is as follows:

- 1 fire axe with brackets
- 1 crowbar with brackets
- 2 hose and ladder straps
- 2 electrical battery hand lights.

A-6.1 Typical Monitor Nozzles.

Figure A-6-1(a) Standard monitor nozzles. (Gear control nozzles are also satisfactory.)

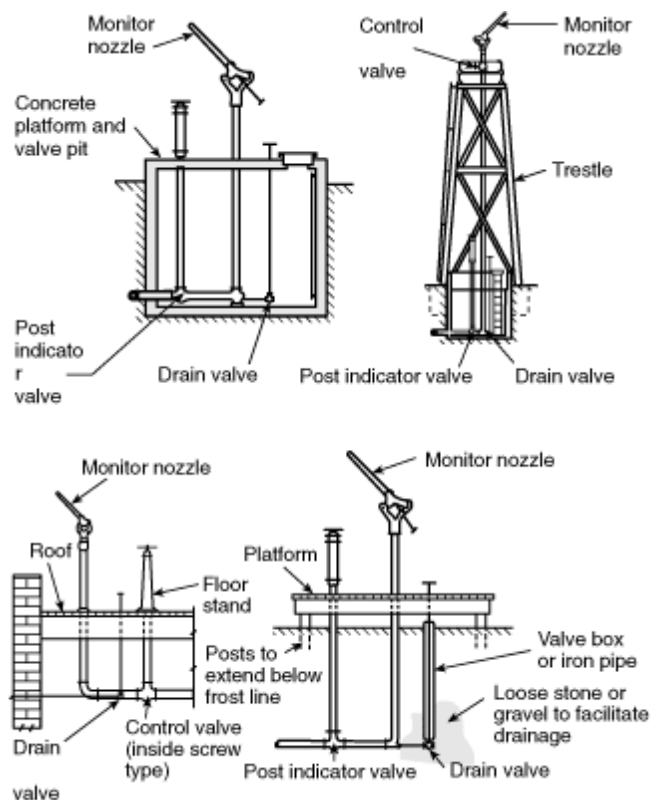

Figure A-6-1(b) Typical hydrant-mounted monitor nozzle



A-7

This standard makes reference to codes and standards published by other organizations. The addresses are as follows:

ACPA American Concrete Pipe Association 8320 Old Courthouse Road Vienna, Virginia 20005

ANSI American National Standards Institute 11 West 42nd Street New York, New York 10036

ASSE American Society of Sanitary Engineering P.O. Box 40362 Bay Village, Ohio 44140

ASTM American Society for Testing and Materials 1916 Race Street Philadelphia, Pennsylvania 19103-1187

AWS American Welding Society 550 N. W. LeJeune Road P. O. Box 351040 Miami, Florida 33125

AWWA American Water Works Association, Inc 666 West Quincy Avenue Denver, Colorado 80235

CSA Canadian Standards Association 178 Rexdale Boulevard Rexdale, Ontario, Canada M9W 1R3

DIPRA Ductile Iron Pipe Research Association 245 Riverchase Parkway, East Suite 0 Birmingham, Alabama 35244

A-7-1

Loop systems for yard piping are recommended for increased reliability and improved hydraulics. Loop systems should be sectionalized by placing valves at branches and at

strategic locations to minimize the extent of impairments.

A-7-1.1

(a) Testing laboratories list or label cast-iron and ductile iron pipe (cement-lined and unlined, coated and uncoated), asbestos-cement pipe and couplings, steel pipe, cooper pipe, fiberglass filament-wound epoxy pipe and couplings, polyethylene pipe, and polyvinyl chloride (PVC) pipe and couplings. Underwriters Laboratories Inc. lists under reexamination service reinforced concrete pipe (cylinder pipe, nonprestressed and prestressed).

(b) *Pipe Standards*. The various types of pipe are usually manufactured to one of the following standards:

AWWA C400, *Standard for Asbestos-Cement Distribution Pipe, 4 in. Through 16 in., for Water and Other Liquids*.

ASTM C296, *Standard Specification for Asbestos-Cement Pressure Pipe*.

AWWA C151, *Ductile Iron Pipe Centrifugally Cast in Metal Molds or Sand-Lined Molds, for Water or Other Liquids*.

AWWA C900, *Polyvinyl Chloride (PVC) Pressure Pipe, 4 in. Through 12 in., for Water and Other Liquids*.

AWWA C300, *Reinforced Concrete Pressure Pipe, Steel-Cylinder Type, for Water and Other Liquids*.

AWWA C301, *Prestressed Concrete Pressure Pipe, Steel-Cylinder Type, for Water and Other Liquids*.

AWWA C302, *Reinforced Concrete Pressure Pipe, Non-Cylinder Type, for Water and Other Liquids*.

AWWA C303, *Reinforced Concrete Pressure Pipe, Steel-Cylinder Type, Pretensioned, for Water and Other Liquids*.

AWWA C200, *Steel Water Pipe 6 in. and Larger*.

A-7-1.2 Pipe Design Manuals.

The following pipe design manuals may be used as guides:

AWWA C401, *Standard Practice for the Selection of Asbestos-Cement Water Pipe*.

Concrete Pipe Handbook, American Concrete Pipe Association.

AWWA C150, *Thickness Design of Ductile Iron Pipe*.

AWWA M11, *Steel Pipe — A Guide for Design and Installation*.

A-7-1.4

Pipe friction losses should be determined on the basis of the Hazen and Williams formula.

$$P = \frac{4.52 Q^{1.85}}{C^{1.85} d^{4.87}}$$

where:

P = Pressure in psi

Q = Flow in gpm

C = Hazen and Williams Coefficient

d = Actual pipe diameter, in inches

Table A-7-1.4

Pipe or Tube	Hazen-Williams “C” Value ¹
Unlined Cast or Ductile Iron	100
Asbestos Cement, Cement-Lined Cast or Ductile Iron, Cement-Lined Steel and Concrete	140
Polyethylene, Polyvinyl Chloride (PVC) and Fiberglass epoxy	150
Copper	150

¹ These values may be reduced by the authority having jurisdiction to be consistent with design procedures.

A-7-2 Coating and Lining Standards.

The following apply to the application of coating and linings:

AWWA C104, *Cement Mortar Lining for Ductile Iron Pipe and Fittings for Water.*

AWWA C105, *Polyethylene Encasement for Ductile Iron Piping for Water and Other Liquids.*

AWWA C203, *Coal-Tar Protective Coatings and Linings for Steel Water Pipelines Enamel and Tape — Hot Applied.*

AWWA C205, *Cement-Mortar Protective Lining and Coating for Steel Water Pipe 4 in. and Larger — Shop Applied.*

AWWA C602, *Cement-Mortar Lining of Water Pipe Lines 4 in. and Larger — in Place.*

A-7-3 Joint Standards.

The following apply to joints used with the various types of pipe:

AWWA C111, *Rubber Gasket Joints for Ductile Iron Pressure Pipe and Fittings.*

AWWA C206, *Field Welding of Steel Water Pipe.*

AWWA C207, *Steel Pipe Flanges for Waterworks Services — Sizes 4 in. Through 144 in.*

ANSI B16.1, *Cast-Iron Pipe Flanges and Flanged Fittings for 25, 125, 250 and 800 lb.*

AWWA C115, *Flanged Ductile Iron Pipe with Threaded Flanges.*

A-7-4 Fittings Standards.

Fittings generally used are cast iron with joints to specifications of the manufacturer of the particular type of pipe. See standards listed in A-7-3. Steel fittings also have some applications. The following standards apply to fittings:

AWWA C110, Ductile Iron and Gray Iron Fittings, 3-in. Through 48-in., for Water and Other Liquids.

AWWA C208, Dimensions for Fabricated Steel Water Pipe Fittings.

ANSI B16.1, Cast-Iron Pipe Flanges and Flanged Fittings for 25, 125, 250 and 800 lb.

A-8 Installation Standards.

The following apply to the installation of pipe and fittings:

AWWA C603, AWWA Standard for the Installation of Asbestos-Cement Water Pipe.

AWWA C600, AWWA Standard for the Installation of Ductile-Iron Water Mains and Their Appurtenances.

Concrete Pipe Handbook, American Concrete Pipe Association.

AWWA M11, Steel Pipe Design and Installation, Steel Pipe Manual.

A Guide for the Installation of Gray Cast-Iron Water Mains, Ductile Iron Pipe Research Association.

A Guide for the Installation of Ductile Iron Pipe, Ductile Iron Pipe Research Association.

Thrust Restraint Design for Ductile Iron Pipe, Ductile Iron Pipe Research Association.

Handbook of PVC Pipe, Uni-Bell Plastic Pipe Association.

A-8-1.1

As there is normally no circulation of water in private fire mains, they require greater depth of covering than do public mains. Greater depth is required in a loose gravelly soil (or in rock) than in compact, clayey soil. Recommended depth of cover above the top of underground yard mains is shown in Figure A-8-1.1.

Figure A-8-1.1

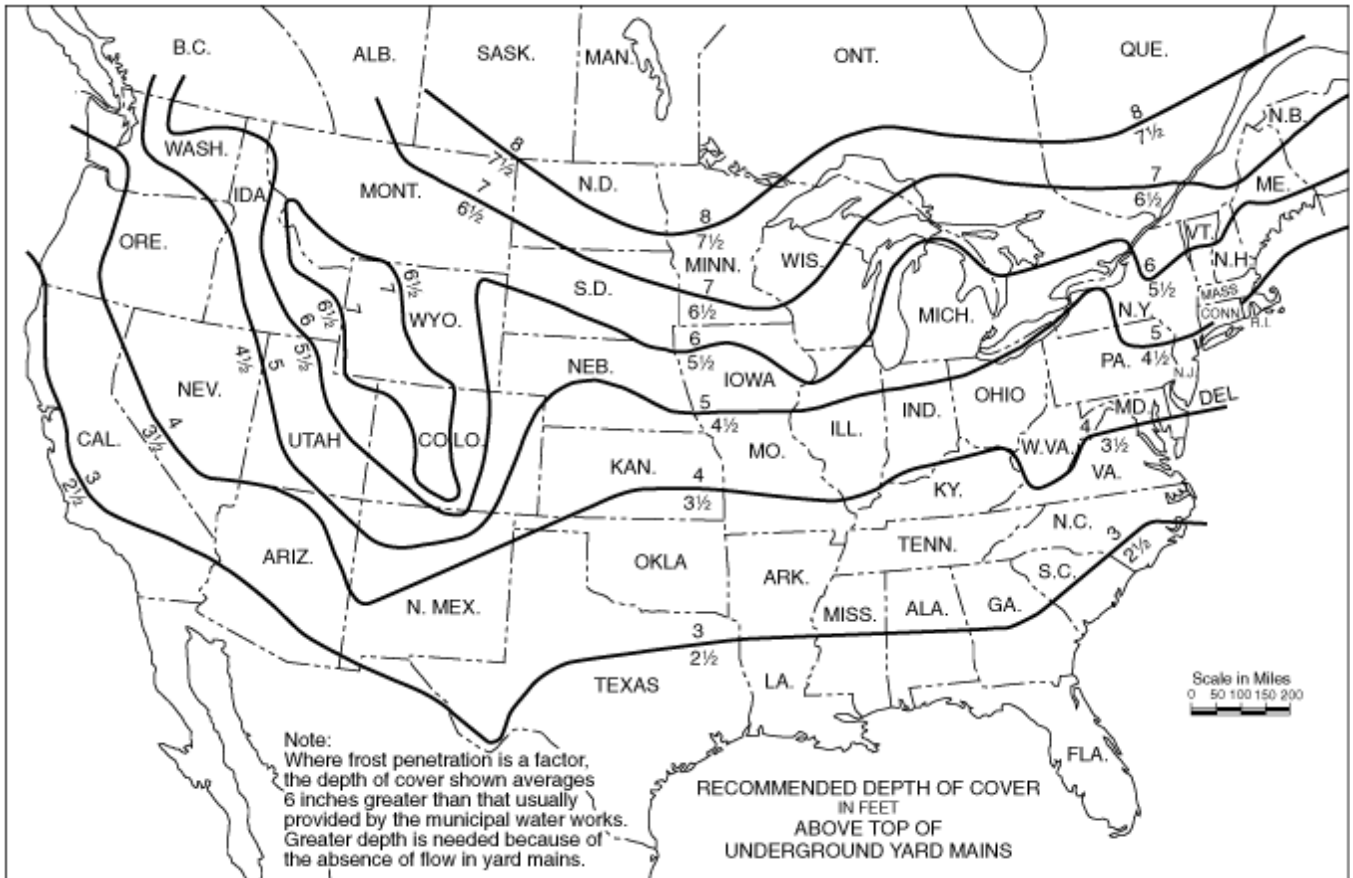

A-8-3.4

Gray cast iron is not considered galvanically dissimilar to ductile iron. Rubber gasket joints (unrestrained push-on or mechanical joints) are not considered connected electrically. Metal thickness should not be considered a protection against corrosive environments. In the case of cast-iron or ductile iron pipe for soil evaluation and external protection systems, see Appendix A of ANSI/AWWA C105/A21.5.

A-8-6.1

Except for the case of welded joints and approved special restrained joints, such as provided by approved mechanical joint retainer glands or locked mechanical and push-on joints, the usual joints for underground pipe are expected to be held in place by the soil in which the pipe is buried. Gasketed push-on and mechanical joints without special locking devices have limited ability to resist separation due to movement of the pipe.

A-8-6.2

It is a fundamental design principle of fluid mechanics that dynamic and static pressures, acting at changes in size or direction of a pipe, produce unbalanced thrust forces at bends, tees, wyes, deadends, reducers, offsets, etc.

This procedure includes consideration of lateral soil pressure and pipe/soil friction, variables that can be reliably determined using present-day soils engineering knowledge.

Refer to A-7-1.1 for a list of references for use in calculating and determining joint restraint systems.

Table A-8-6.2 Thrust at Fittings at 100 PSI Water Pressure for Ductile Iron and PVC Pipe

	Total Pounds				
	Dead End	90° Bend	45° Bend	22 ¹ / ₂ ° Bend	11 ¹ / ₄ ° Bend
a.					
	1,810	2,559	1,385	706	355
	3,739	5,288	2,862	1,459	733
	6,433	9,097	4,923	2,510	1,261
	9,677	13,685	7,406	3,776	1,897
	13,685	19,353	10,474	5,340	2,683
	18,385	26,001	14,072	7,174	3,604
	23,779	33,628	18,199	9,278	4,661
	29,865	42,235	22,858	11,653	5,855
	36,644	51,822	28,046	14,298	7,183
	52,279	73,934	40,013	20,398	10,249
	80,425	113,738	61,554	31,380	15,766
	115,209	162,931	88,177	44,952	22,585
	155,528	219,950	119,036	60,684	30,489
	202,683	286,637	155,127	79,083	39,733
	256,072	362,140	195,989	99,914	50,199
	298,121	421,606	288,172	116,321	58,440
	338,707	479,004	259,235	132,157	66,390

To determine thrust at pressure other than 100 psi, multiply the thrust obtained in the table by the ratio of the pressure to 100. For example, the thrust on a 12 in., 90° bend at 125 psi is

$$\frac{125}{100} = 24,191 \text{ pounds}$$

Figure A-8-6.2(a) Thrust forces acting on a bend

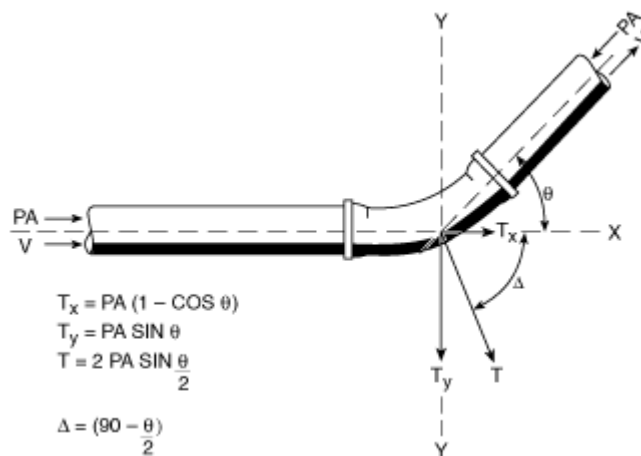
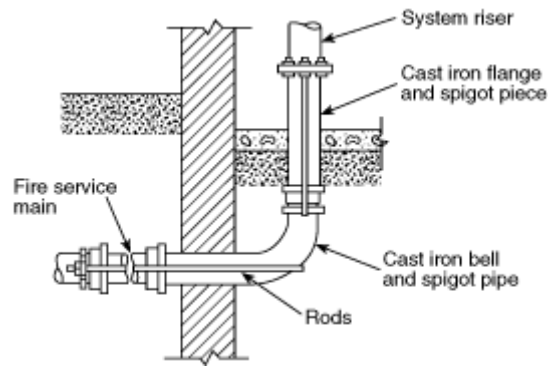

Figure A-8-6.2(b) Typical connection to a fire protection system riser



A-8-6.2.1

Concrete thrust blocks are one of the most common methods of restraint now in use, provided stable soil conditions prevail and space requirements permit placement. Successful blocking is dependent upon factors such as location, availability and placement of concrete, and possibility of disturbance by future excavations.

Thrust blocks are generally categorized into two groups: bearing and gravity blocks.

Figure A-8-6.2.1(a) depicts a typical bearing thrust block on a horizontal bend. Resistance is provided by transferring the thrust force to the soil through the larger bearing area of the block such that the resultant pressure against the soil does not exceed the horizontal bearing strength of the soil. Design of thrust blocks consists of determining the appropriate bearing area of the block for a particular set of conditions. The parameters involved in the design include pipe size, design pressure, angle of the bend (or configuration of the fitting involved), and the horizontal bearing strength of the soil.

Figure A-8-6.2.1(a) Bearing thrust block

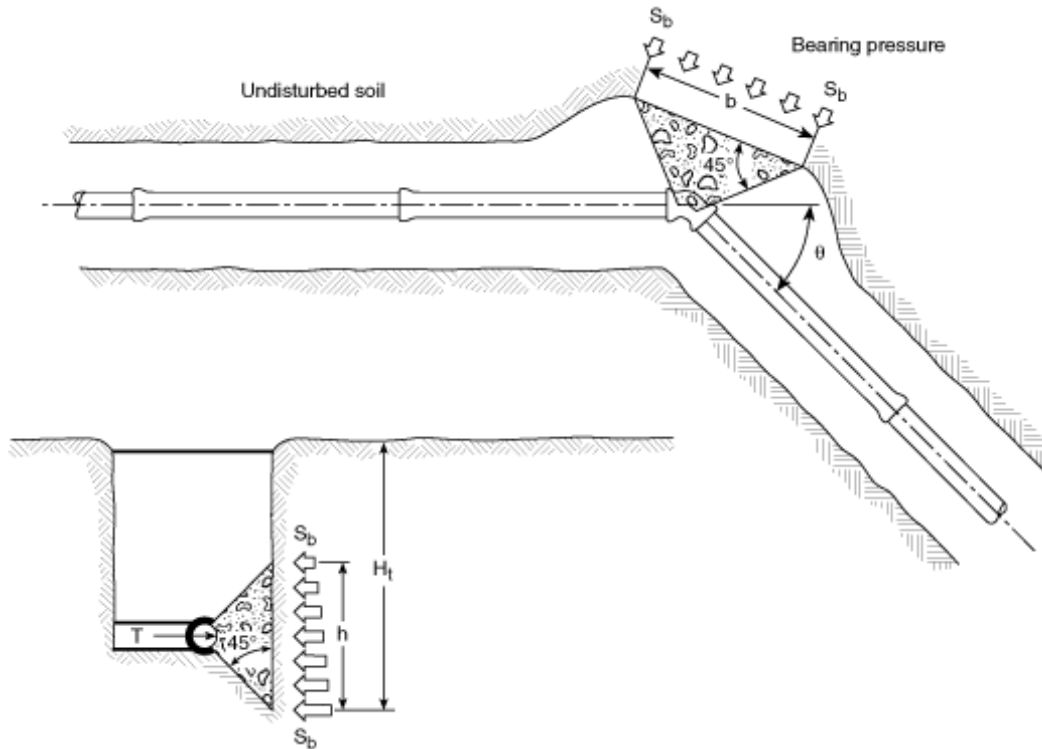

The following are general criteria for bearing block design.

- (1) Bearing surface should, where possible, be placed against undisturbed soil. Where it is not possible, the fill between the bearing surface and undisturbed soil must be compacted to at least 90 percent Standard Proctor density.
- (2) Block height (h) should be equal to or less than one-half the total depth to the bottom of the block, (H_t), but not less than the pipe diameter (D).
- (3) Block height (h) should be chosen such that the calculated block width (b) varies between one and two times the height.

The required bearing block area is

$$A_b = hb = \frac{T}{S_b}$$

Then, for a horizontal bend,

$$b = hb = \frac{2 S_t PA \sin(\theta/2)}{h S_b}$$

where S_t is a safety factor (usually 1.5 for thrust block design). A similar approach may be used to design bearing blocks to resist the thrust forces at tees, dead ends, etc. Typical values for conservative horizontal bearing strengths of various soil types are listed in Table A-8-6.2.1.

In lieu of the values for soil bearing strength shown in Table A-8-6.2.1, a designer might choose to use calculated Rankine passive pressure (P_p) or other determination of soil bearing strength based on actual soil properties.

Table A-8-6.2.1 Horizontal Bearing Strengths

Soil	*Bearing Strength S_b (lb/ft ²)
Muck	0
Soft Clay	1,000
Silt	1,500
Sandy Silt	3,000
Sand	4,000
Sandy Clay	6,000
Hard Clay	9,000

* Although the above bearing strength values have been used successfully in the design of thrust blocks and are considered to be conservative, their accuracy is totally dependent on accurate soil identification and evaluation. The ultimate responsibility for selecting the proper bearing strength of a particular soil type must rest with the design engineer.

Gravity thrust blocks may be used to resist thrust at vertical down bends. In a gravity thrust block, the weight of the block is the force providing equilibrium with the thrust force. The design problem is then to calculate the required volume of the thrust block of a known density. The vertical component of the thrust force in Figure A-8-6.2.1(b) is balanced by the weight of the block.

Figure A-8-6.2.1(b) Gravity thrust block

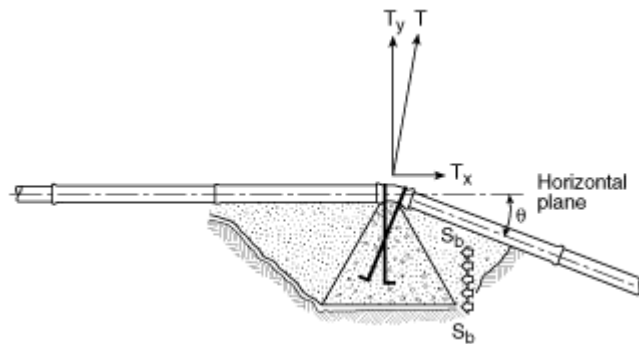

It can easily be shown that $T_y = PA \sin \theta$. The required volume of the block is

$$V_g = \frac{S_t PA \sin \theta}{W_m}$$

where W_m = density of the block material. In a case such as the one shown, the horizontal component of the thrust force

$$T_x = PA (1 - \cos \theta)$$

must be resisted by the bearing of the right side of the block against the soil. Analysis

of this aspect will follow the same principles as the above section on bearing blocks.

A-8-6.2.8

Examples of materials and the standards covering these materials are:

- (a) *Clamps*. Steel (see Note).
- (b) *Rods*. Steel (see Note).
- (c) *Bolts*. Steel (ASTM A307, *Standard Specification for Carbon Steel Bolts and Studs*).
- (d) *Washers*. Steel (see Note 1). Cast Iron (Class A cast iron as defined by ASTM A126, *Standard Specification for Gray Iron Casting for Valves, Flanges and Pipe Fittings*).
- (e) *Anchor Straps and Plug Straps*. Steel (See Note).
- (f) *Rod Couplings or Turnbuckles*. Malleable iron (ASTM A197, *Standard Specification for Cupola Malleable Iron*).

NOTE: Steel of modified range merchant quality as defined in U.S. Federal Standard No. 66C, *Standard for Steel Chemical Composition and Harden Ability*, April 18, 1967, change notice No. 2, April 16, 1970, as promulgated by the U.S. Federal Government General Services Administration.

The above-listed materials do not preclude the use of other materials that will also satisfy the requirements of this section.

A-9-2.1

See Figure A-9-2.1.

Figure A-9-2.1 Typical contractor's material and test certificate for private fire service mains (continued on next page)

Contractor's Material and Test Certificate for Private Fire Service Mains

PROCEDURE

Upon completion of work, inspection and tests shall be made by the contractor's representative and witnessed by an owner's representative. All defects shall be corrected and system left in service before contractor's personnel finally leave the job.

A certificate shall be filled out and signed by both representatives. Copies shall be prepared for approving authorities, owners, and contractor. It is understood the owner's representative's signature in no way prejudices any claim against contractor for faulty material, poor workmanship, or failure to comply with approving authority's requirements or local ordinances.

PROPERTY NAME	DATE
---------------	------

PROPERTY ADDRESS

PLANS	ACCEPTED BY APPROVING AUTHORITIES (NAMES)		
	ADDRESS		
	INSTALLATION CONFORMS TO ACCEPTED PLANS	<input type="checkbox"/> YES	<input type="checkbox"/> NO
	EQUIPMENT USED IS APPROVED IF NO, STATE DEVIATIONS	<input type="checkbox"/> YES	<input type="checkbox"/> NO

INSTRUCTIONS	HAS PERSON IN CHARGE OF FIRE EQUIPMENT BEEN INSTRUCTED AS TO LOCATION OF CONTROL VALVES AND CARE AND MAINTENANCE OF THIS NEW EQUIPMENT? IF NO, EXPLAIN	<input type="checkbox"/> YES	<input type="checkbox"/> NO
	HAVE COPIES OF APPROPRIATE INSTRUCTIONS AND CARE AND MAINTENANCE CHARTS BEEN LEFT ON PREMISES? IF NO, EXPLAIN	<input type="checkbox"/> YES	<input type="checkbox"/> NO

LOCATION SUPPLIES BUILDINGS

PIPES AND JOINTS	PIPE TYPES AND CLASS	TYPE JOINT		
	PIPE CONFORMS TO _____ STANDARD		<input type="checkbox"/> YES	<input type="checkbox"/> NO
	FITTINGS CONFORM TO _____ STANDARD IF NO, EXPLAIN		<input type="checkbox"/> YES	<input type="checkbox"/> NO
	BURIED JOINTS NEEDING ANCHORAGE CLAMPED, STRAPPED, OR BLOCKED IN ACCORDANCE WITH _____ STANDARD IF NO, EXPLAIN		<input type="checkbox"/> YES	<input type="checkbox"/> NO

TEST DESCRIPTION

FLUSHING: Flow the required rate until water is clear as indicated by no collection of foreign material in burlap bags at outlets such as hydrants and blow-offs. Flush at flows not less than 390 GPM (1476 L/min) for 4-inch pipe, 610 GPM (2309 L/min) for 5-inch pipe, 880 GPM (3331 L/min) for 6-inch pipe, 1560 GPM (5905 L/min) for 8-inch pipe, 2440 GPM (9235 L/min) for 10-inch pipe, and 3520 GPM (13323 L/min) for 12-inch pipe. When supply cannot produce stipulated flow rates, obtain maximum available.

HYDROSTATIC: Hydrostatic tests shall be made at not less than 200 psi (13.8 bars) for two hours or 50 psi (3.4 bars) above static pressure in excess of 150 psi (10.3 bars) for two hours.

LEAKAGE: New pipe laid with rubber gasketed joints shall, if the workmanship is satisfactory, have little or no leakage at the joints. The amount of leakage at the joints shall not exceed 2 qts. per hr. (1.89 L/h) per 100 joints irrespective of pipe diameter. The amount of allowable leakage specified above may be increased by 1 fl oz per in. valve diameter per hr. (30 mL/25 mm/h) for each metal seated valve isolating the test section. If dry barrel hydrants are tested with the main valve open, so the hydrants are under pressure, an additional 5 oz per minute (150 mL/min) leakage is permitted for each hydrant.

FLUSHING TESTS	NEW PIPING FLUSHED ACCORDING TO _____ STANDARD BY (COMPANY) IF NO, EXPLAIN	<input type="checkbox"/> YES	<input type="checkbox"/> NO
	HOW FLUSHING FLOW WAS OBTAINED <input type="checkbox"/> PUBLIC WATER <input type="checkbox"/> TANK OR RESERVOIR <input type="checkbox"/> FIRE PUMP	THROUGH WHAT TYPE OPENING <input type="checkbox"/> HYDRANT BUTT <input type="checkbox"/> OPEN PIPE	
	LEAD-INS FLUSHED ACCORDING TO _____ STANDARD BY (COMPANY) IF NO, EXPLAIN	<input type="checkbox"/> YES	<input type="checkbox"/> NO
	HOW FLUSHING FLOW WAS OBTAINED <input type="checkbox"/> PUBLIC WATER <input type="checkbox"/> TANK OR RESERVOIR <input type="checkbox"/> FIRE PUMP	THROUGH WHAT TYPE OPENING <input type="checkbox"/> Y CONN. TO FLANGE & SPIGOT <input type="checkbox"/> OPEN PIPE	

Figure A-9-2.1 Typical contractor's material and test certificate for private fire service mains (continued)

HYDROSTATIC TEST	ALL NEW PIPING HYDROSTATICALLY TESTED AT _____ PSI FOR _____ HOURS		BURIED JOINTS COVERED <input type="checkbox"/> YES <input type="checkbox"/> NO
	LEAKAGE TEST	TOTAL AMOUNT OF LEAKAGE MEASURED _____ GALS. _____ HOURS	NO LEAKAGE ALLOWED FOR VISIBLE JOINTS
		ALLOWABLE LEAKAGE (BURIED) _____ GALS. _____ HOURS	NO LEAKAGE ALLOWED FOR VISIBLE JOINTS
HYDRANTS	NUMBER INSTALLED	TYPE AND MAKE	ALL OPERATE SATISFACTORILY <input type="checkbox"/> YES <input type="checkbox"/> NO
CONTROL VALVES	WATER CONTROL VALVES LEFT WIDE OPEN IF NO, STATE REASON		<input type="checkbox"/> YES <input type="checkbox"/> NO
	HOSE THREADS OF FIRE DEPARTMENT CONNECTIONS AND HYDRANTS INTERCHANGEABLE WITH THOSE OF FIRE DEPARTMENT ANSWERING ALARM		<input type="checkbox"/> YES <input type="checkbox"/> NO
REMARKS	DATE LEFT IN SERVICE _____ ADDITIONAL COMMENTS: _____		
SIGNATURES	NAME OF INSTALLING CONTRACTOR		
	TESTS WITNESSED BY		
	FOR PROPERTY OWNER (SIGNED)	TITLE	DATE
	FOR INSTALLING CONTRACTOR (SIGNED)	TITLE	DATE
ADDITIONAL EXPLANATION AND NOTES			

A-9-2.2

(a) Hydrostatic tests should be made before the joints are covered so that any leaks may be readily detected. Thrust blocks should be sufficiently hardened before hydrostatic testing is begun. If the joints are covered with backfill prior to testing, the contractor remains responsible for locating and correcting any leakage in excess of that permitted in 9-2.3.2 and 9-2.3.3.

(b) The pipeline should be prepared 24 hours prior to testing by filling it with water, in a manner to remove all air. The test pressure should be applied to stabilize the system. This should minimize losses due to entrapped air, changes in water temperature, distention of components under pressure, movement of gaskets, and absorption of air by the water and water by the pipe wall.

A-9-2.3.1

A recommended test procedure is as follows: The water pressure is to be increased in 50-psi (3.4-bar) increments until the test pressure described in 9-2.3.1 is attained. After each increase in pressure, observations are to be made of the stability of the joints. These observations are to include such items as protrusion or extrusion of the gasket, leakage, or

other factors likely to affect the continued use of a pipe in service. During the test, the pressure is not to be increased by the next increment until the joint has become stable. This applies particularly to movement of the gasket. After the pressure has been increased to the required maximum value and held for one hour, the pressure is to be decreased to 0 psi while observations are made for leakage. The pressure is again to be slowly increased to the value specified in 9-2.3.1 and held for one more hour while observations are made for leakage and the leakage measurement is made.

A-9-2.3.2

New pipe laid with rubber gasketed joints should, if the workmanship is satisfactory, have no leakage at the joints. Unsatisfactory amounts of leakage usually result from twisted, pinched, or cut gaskets. However, some leakage might result from small amounts of grit or small imperfections in the surfaces of the pipe joints.

A-9-2.3.3

The use of a blind flange or skillet is preferred for use when hydrostatically testing segments of new work. Metal seated valves are susceptible to developing slight imperfections during transport, installation, and operation and thus may be likely to leak more than one fluid ounce per inch of valve diameter. For this reason, the blind flange should be used when hydrostatically testing.

Appendix B Referenced Publications

B-1

The following documents or portions thereof are referenced within this standard for informational purposes only and thus are not considered part of the requirements of this document. The edition indicated for each reference is the current edition as of the date of the NFPA issuance of this document.

B-1.1 NFPA Publications.

National Fire Protection Association, 1 Batterymarch Park, P.O. Box 9101, Quincy, MA 02269-9101.

NFPA 13, *Standard for the Installation of Sprinkler Systems*, 1994 edition.

NFPA 13E, *Guide for Fire Department Operations in Properties Protected by Sprinkler and Standpipe Systems*, 1995 edition.

NFPA 20, *Standard for the Installation of Centrifugal Fire Pumps*, 1993 edition.

NFPA 22, *Standard for Water Tanks for Private Fire Protection*, 1993 edition.

NFPA 72, *National Fire Alarm Code*, 1993 edition.

NFPA 1962, *Standard for the Care, Use, and Service Testing of Fire Hose Including Couplings and Nozzles*, 1993 edition.

B-1.1.1

The following NFPA publications contain additional information relevant to this standard:

NFPA 11, *Standard for Low Expansion Foam*, 1994 edition.

NFPA 14, *Standard for the Installation of Standpipe and Hose Systems*, 1993 edition.

NFPA 15, *Standard for Water Spray Fixed Systems for Fire Protection*, 1990 edition.

NFPA 16, *Standard for the Installation of Deluge Foam-Water Sprinkler and Foam-Water Spray Systems*, 1995 edition.

NFPA 1963, *Standard for Fire Hose Connections*, 1993 edition.

B-1.2 ACPA Publication.

American Concrete Pipe Association, 8320 Old Courthouse Road, Vienna, VA 20005.

Concrete Pipe Handbook.

B-1.3 ANSI Publication.

American National Standards Institute, 11 West 42nd Street, New York, NY 10036.

ANSI B16.1, *Cast-Iron Pipe Flanges and Flanged Fittings for 25, 125, 250 and 800 lb*, 1989.

B-1.4 ASTM Publications.

American Society for Testing and Materials, 1916 Race Street, Philadelphia, PA 19103.

ASTM A126, *Specification for Gray Iron Castings for Valves, Flanges and Pipe Fittings*, 1993.

ASTM A197, *Specification for Cupola Malleable Iron*, 1987.

ASTM A307, *Specification for Carbon Steel Bolts and Studs, 60,000 psi Tensile Strength*, 1994.

ASTM C296, *Standard Specification for Asbestos-Cement Pressure Pipe*, 1988.

ASTM E380, *Standard Practice for Use of the International System of Units*, 1991.

B-1.5 AWWA Publications.

American Water Works Association Inc., 666 West Quincy Avenue, Denver, CO 80235.

AWWA C104, *Cement Mortar Lining for Ductile Iron Pipe and Fittings for Water*, 1990.

AWWA C105, *Polyethylene Encasement for Ductile Iron Piping for Water and Other Liquids*, 1988.

AWWA C110, *Ductile Iron and Gray Iron Fittings, 3-in. Through 48-in. for Water and Other Liquids*, 1987.

AWWA C111, *Rubber Gasket Joints for Ductile Iron Pressure Pipe and Fittings*, 1990.

AWWA C115, *Flanged Ductile Iron Pipe with Threaded Flanges*, 1988.

AWWA C150, *Thickness Design of Ductile Iron Pipe*, 1981.

AWWA C151, *Ductile Iron Pipe Centrifugally Cast in Metal Molds or Sandlined Molds, for Water or Other Liquids*, 1986.

AWWA C200, *Steel Water Pipe 6 in. and Larger*, 1986.

AWWA C203, *Coal-Tar Protective Coatings and Linings for Steel Water Pipelines Enamel and Tape—Hot Applied*, 1986.

AWWA C205, *Cement-Mortar Protective Lining and Coating for Steel Water Pipe 4 in. and Larger—Shop Applied*, 1989.

AWWA C206, *Field Welding of Steel Water Pipe*, 1988.

AWWA C207, *Steel Pipe Flanges for Waterworks Services—Sizes 4 in. Through 144 in.*, 1978.

AWWA C208, *Dimensions for Fabricated Steel Water Pipe Fittings*, 1983.

AWWA C300, *Reinforced Concrete Pressure Pipe, Steel-Cylinder Type, for Water and Other Liquids*, 1989.

AWWA C301, *Prestressed Concrete Pressure Pipe, Steel-Cylinder Type, for Water and Other Liquids*, 1984.

AWWA C302, *Reinforced Concrete Pressure Pipe, Non-Cylinder Type, for Water and Other Liquids*, 1987.

AWWA C303, *Reinforced Concrete Pressure Pipe, Steel-Cylinder Type, Pretensioned, for Water and Other Liquids*, 1987.

AWWA C400, *Standard for Asbestos-Cement Distribution Pipe, 4 in. Through 16 in., for Water and Other Liquids*, 1980.

AWWA C401, *Standard Practice for the Selection of Asbestos-Cement Water Pipe*, 1983.

AWWA C600, *Standard for the Installation of Ductile-Iron Water Mains and Their Appurtenances*, 1982.

AWWA C602, *Cement-Mortar Lining of Water Pipe Lines 4 in. and Larger—in Place*, 1989.

AWWA C603, *Standard for the Installation of Asbestos-Cement Water Pipe*, 1978.

AWWA C900, *Polyvinyl Chloride (PVC) Pressure Pipe, 4 in. Through 12 in., for Water and Other Liquids*, 1989.

AWWA M11, *Steel Pipe—A Guide for Design and Installation*, 1989.

AWWA Manual 14, *Backflow Prevention and Cross Connection Control*, 1990 edition.

AWWA Manual 17, *Installation, Maintenance, and Field Testing of Fire Hydrants*, 1980 edition.

B-1.6 DIRPA Publications.

Ductile Iron Pipe Research Association, 245 Riverchase Parkway, East, Suite 0,
Birmingham, AL 35244.

A Guide for the Installation of Ductile Iron Pipe.

A Guide for the Installation of Gray Cast-Iron Water Mains.

Thrust Restraint Design for Ductile Iron Pipe.

B-1.7 UBPPA Publication.

Uni-Bell Plastic Pipe Association, 2655 Ville Creek Drive, Dallas, TX 75234.

Handbook of PVC Pipe.

Formal Interpretation

Formal Interpretation

NFPA 24

Private Fire Service Mains and Their Appurtenances

1995 Edition

Reference: 8-6.1

F.I. 81-4

Question: Is it the intent of 8-6.1 that all tees, plugs, caps, bends, and hydrant branches on pipe installed underground shall be restrained against movement regardless of type of joint?

Answer: No. Gasketed push-on and mechanical joints without special locking devices have limited ability to resist separation due to movement of the pipe. Therefore, all tees, plugs, caps, bends, and hydrant branches having such joints shall be restrained against movement. For the case of welded joints and approved special restrained joints, such as provided by approved mechanical joint retainer glands, locked mechanical and push-on joints, or locking threaded rings, no additional restraint against movement is required.

Issue Edition: 1981

Reference: 8-6.1

Date: January 1983

Copyright © 1992 All Rights Reserved
NATIONAL FIRE PROTECTION ASSOCIATION

Formal Interpretation

NFPA 24

Private Fire Service Mains and Their Appurtenances

Copyright NFPA

1995 Edition

Reference: 9-2.3.1

F.I. 81-3

Question: With a pump shutoff pressure of 195 psi, what should the hydrostatic test system pressure be?

Answer: 245 psi.

Issue Edition: 1981

Reference: 8-9.3.1

Date: December 1981

Copyright © 1992 All Rights Reserved
NATIONAL FIRE PROTECTION ASSOCIATION

Formal Interpretation

NFPA 24

**Private Fire Service Mains
and Their Appurtenances**

1995 Edition

Reference: 9-2.3.2

F.I. 81-2

Question: Would the following method of measuring leakage conform to the intent of 9-2.3.2?

- (a) Record gage reading and pressure drop that occurred during the test period.
- (b) Repressure the system to the starting pressure.
- (c) Bleed off the water through an equal pressure drop into the measuring container.

For new pipe, the amount of leakage at the joints would be less than 2 quarts per hour per 100 gaskets irrespective of pipe diameter.

Answer: Yes, providing the test pressure at the end of the test is at least the amount specified in 9-2.3.1.

Issue Edition: 1981

Reference: 8-9.3.2

Date: July 1981

Copyright © 1992 All Rights Reserved
NATIONAL FIRE PROTECTION ASSOCIATION

[Click here to view and/or print an Adobe® Acrobat®
version of the index for this document](#)